

no longer available - archive entry Alternative article: O5H504

When selecting an alternative article and accessories please note that technical data may differ!

**efector200**

OT5002



OTT-FNKG

Photoelectric sensors

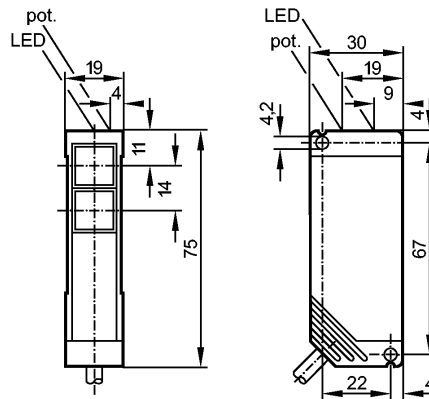

1: potentiometer

Receiver in lower lens, Transmitter in upper lens



Product characteristics

Diffuse reflection sensor

Rectangular, plastics

Cable

Range 4...200mm (referred to white paper 200 x 200 mm)

adjustable

Electrical data

Electrical design

DC NPN

Operating voltage [V]

10...55 DC

Current consumption [mA]

40 (24 V)

Type of light

Infrared light 880 nm

Protection class

II

Reverse polarity protection

yes

Outputs

Output function

light-on / dark-on programmable

Voltage drop [V]

< 2.5

Current rating [mA]

250

Short-circuit protection

yes (non-latching)

Overload protection

yes

Switching frequency [Hz]

150

Monitoring range

Range [mm]

4...200 (referred to white paper 200 x 200 mm)

Light spot diameter [mm]

187 ( at maximum range )

Excess gain graphs

**OT5002 - Diffuse reflection sensor - eclass: 27270903 / 27-27-09-03**

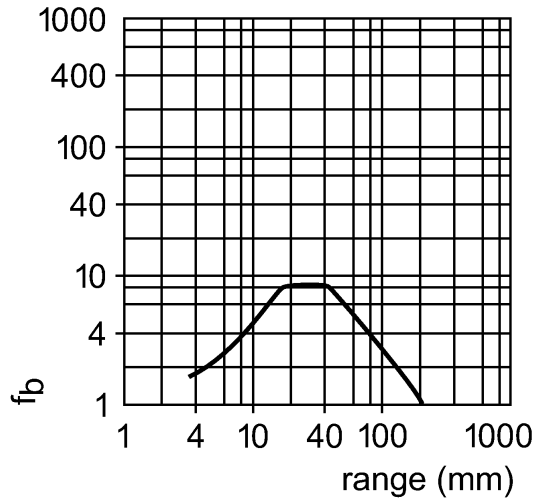

Environment	
Ambient temperature [°C]	-25...60
Protection	IP 67
Tests / approvals	
EMC	EN 60947-5-2 EN 55011: class B
MTTF [Years]	583
Mechanical data	
Housing materials	PBT
Lens material	PMMA
Weight [kg]	0.205
Displays / operating elements	
Output status indication LED	yellow
Power LED	green
Electrical connection	
Connection	PVC cable / 2 m; 3 x 0.34 mm <sup>2</sup>

**Wiring**

Core colors

- BN brown
- BU blue
- BK black

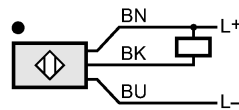
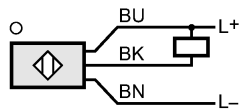

**Accessories**

Accessories (included)	Angle bracket; E20441; screwdriver
Remarks	
Pack quantity [piece]	1

ifm efector, inc. • 1100 Atwater Drive • Malvern • PA 19355 — We reserve the right to make technical alterations without prior notice. — US — OT5002 — 06.03.2003

no longer available - archive entry Alternative article: O5H504

When selecting an alternative article and accessories please note that technical data may differ!