

no longer available - archive entry Alternative article: O5E502 + E21122

When selecting an alternative article and accessories please note that technical data may differ!

efector200

OL5018



OLE-FNKG/US-100

Photoelectric sensors

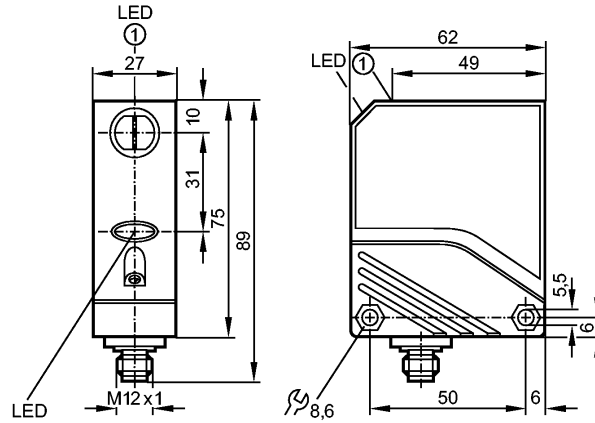

1: pushbutton



Product characteristics

Through-beam sensor

Rectangular, plastics

Quick disconnect

Function check output

Receiver

Sensing range 25m

Electrical data

Electrical design

DC NPN

Operating voltage [V]

10...36 DC

Current consumption [mA]

< 30

Type of light

Infrared light 880 nm

Protection class

II

Reverse polarity protection

yes

Overvoltage protection [V]

yes

Outputs

Output function

light-on / dark-on programmable

Voltage drop

- Switching output [V]

< 2.5

- Function check output [V]

< 3.5

Current rating

- Switching output [mA]

100

- Function check output [mA]

10

Short-circuit protection

yes (non-latching)

Switching frequency [Hz]

500

Monitoring range

Sensing range [m]

25

Excess gain graphs

OL5018 - Through-beam sensor - eclass: 27270901 / 27-27-09-01

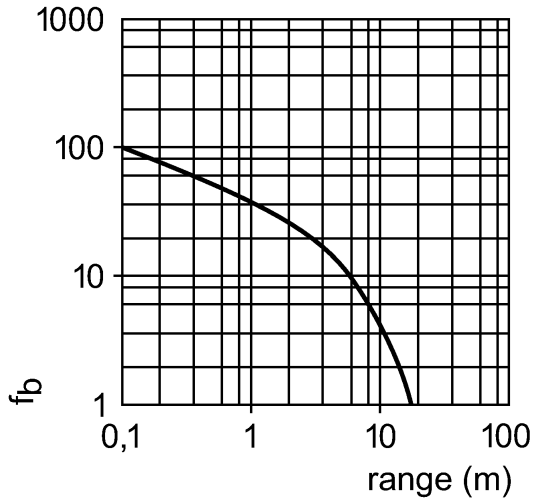

Environment	
Ambient temperature [°C]	-25...80
Protection	IP 67
Tests / approvals	
EMC	EN 60947-5-2 EN 55011: class B
Mechanical data	
Housing materials	PA; PBT
Lens material	PMMA
Weight [kg]	0.176
Displays / operating elements	
Output status indication LED	yellow
Power LED	green
Function display LED	red
Electrical connection	
Connection	M12 connector

Wiring

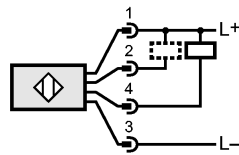

2: function check

Remarks	
Pack quantity [piece]	1

ifm efector, inc. • 1100 Atwater Drive • Malvern • PA 19355 — We reserve the right to make technical alterations without prior notice. — US — OL5018 — 06.03.2003
 no longer available - archive entry Alternative article: O5E502 + E21122
 When selecting an alternative article and accessories please note that technical data may differ!