

**OG5124**

OGH-HPKG/US/90°/200MM

Photoelectric sensors

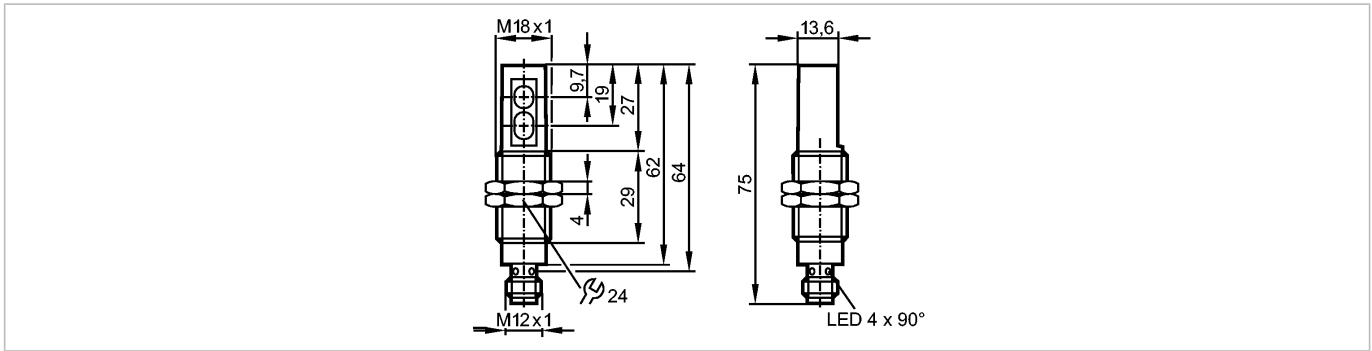

**Product characteristics**

Diffuse reflection sensor
Threaded type
Quick disconnect
Background suppression
Range 200mm (Range referred to white paper 200 x 200 mm, 90 % remission)

**Electrical data**

Electrical design	DC PNP
Operating voltage [V]	10...30 DC
Current consumption [mA]	25
Type of light	red light 625 nm
Protection class	II
Reverse polarity protection	yes

**Outputs**

Output function	light-on mode
Voltage drop [V]	< 2.5
Current rating [mA]	200
Short-circuit protection	yes (non-latching)
Overload protection	yes
Switching frequency [Hz]	1000

**Monitoring range**

Range [mm]	200 (Range referred to white paper 200 x 200 mm, 90 % remission)
Light spot diameter [mm]	< 28 ( at maximum range )

**Environment**

Ambient temperature [°C]	-25...60
Protection	IP 68

**Tests / approvals**

EMC	EN 60947-5-2 EN 55011: class B
MTTF [Years]	541

**Mechanical data**

Housing materials	high-grade stainless steel; ABS
Lens material	PMMA
Weight [kg]	0.063

**Displays / operating elements**

**OG5124**

OGH-HPKG/US/90°/200MM

**Photoelectric sensors**

Output status indication	LED	yellow
Power	LED	green

**Electrical connection**

Connection	M12 connector
------------	---------------

**Wiring**

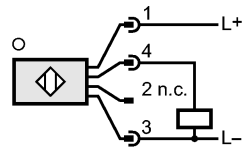

**Accessories**

Accessories (included)	2 nuts; 2 lock washers (Steel galvanized)
------------------------	---

**Remarks**

Pack quantity	[piece]	1
---------------	---------	---