



Model Number

NJ15+U4+N

Features

- Comfort series
- 15 mm flush

Accessories

- MHW 01**
Modular mounting bracket
- MH 04-2681F**
Mounting aid for VariKont, +U1+ and +U9*
- MH 04-2057B**
Mounting aid for VariKont and +U1+

Technical Data

General specifications

Switching function	Normally closed (NC)
Output type	NAMUR
Rated operating distance	s_n 15 mm
Installation	flush
Assured operating distance	s_a 0 ... 12.15 mm
Reduction factor r_{Al}	0.4
Reduction factor r_{Cu}	0.3
Reduction factor r_{304}	0.85
Output type	2-wire

Nominal ratings

Nominal voltage	U_o 8.2 V (R_i approx. 1 k Ω)
Switching frequency	f 0 ... 120 Hz
Current consumption	
Measuring plate not detected	\geq 3 mA
Measuring plate detected	\leq 1 mA

Ambient conditions

Ambient temperature	-25 ... 100 °C (-13 ... 212 °F)
---------------------	---------------------------------

Mechanical specifications

Connection type	screw terminals
Core cross-section	\leq 2.5 mm ²
Housing material	PBT/metal
Sensing face	PBT
Degree of protection	IP68

General information

Use in the hazardous area	see instruction manuals
Category	1G; 2G; 1D

Compliance with standards and directives

Standard conformity	
NAMUR	EN 60947-5-6:2000 IEC 60947-5-6:1999
Standards	EN 60947-5-2:2007 IEC 60947-5-2:2007

Approvals and certificates

FM approval	
Control drawing	116-0165
UL approval	cULus Listed, General Purpose
CSA approval	cCSAus Listed, General Purpose
CCC approval	CCC approval / marking not required for products rated \leq 36 V

Dimensions

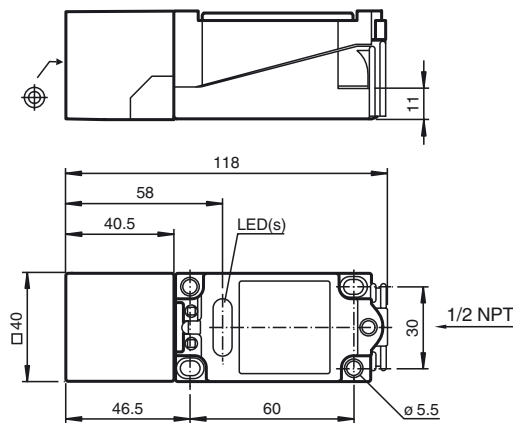

Electrical Connection

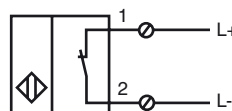

Release date: 2017-03-24 08:51 Date of issue: 2017-03-24 106674_eng.xml

Equipment protection level Ga

Effective internal inductivity C_i
 Effective internal inductance L_i
 Ambient temperature

$\leq 140 \text{ nF}$; a cable length of 10 m is considered.

$\leq 130 \text{ }\mu\text{H}$; a cable length of 10 m is considered.

Details of the correlation between the type of circuit connected, the maximum permissible ambient temperature, the temperature class, and the effective internal reactance values can be found on the EC-type examination certificate. **Note:** Use the temperature table for category 1 !!! The 20 % reduction in accordance with EN 1127-1 has already been applied to the temperature table for category 1.

Release date: 2017-03-24 08:51 Date of issue: 2017-03-24 106674_eng.xml

Equipment protection level Gb

Effective internal inductivity C_i
Effective internal inductance L_i
Maximum permissible ambient temperature T_{amb}

$\leq 140 \text{ nF}$; a cable length of 10 m is considered.

$\leq 130 \text{ }\mu\text{H}$; a cable length of 10 m is considered.

Details of the correlation between the type of circuit connected, the maximum permissible ambient temperature, the temperature class, and the effective internal reactance values can be found on the EC-type examination certificate.

Equipment protection level Da

Instruction

Device category 1D

EC-Type Examination Certificate

CE marking

ATEX marking

Standards

Appropriate type

Effective internal inductivity C_i

Effective internal inductance L_i

General

Permissible ambient temperature range

Installation, commissioning

Maintenance

Special conditions

Protection from mechanical danger

Electrostatic charge

Manual electrical apparatus for hazardous areas

for use in hazardous areas with combustible dust

PTB 00 ATEX 2032 X

 0102

 II 1D Ex ia IIC T135°C Da

The Ex-related marking can also be printed on the enclosed label.

EN 60079-0:2012+A11:2013 EN 60079-11:2012

Ignition protection "Intrinsic safety" Use is restricted to the following stated conditions

NJ 15+U.+N...

≤ 140 nF ; a cable length of 10 m is considered.

≤ 130 μ H ; a cable length of 10 m is considered.

The apparatus has to be operated according to the appropriate data in the data sheet and in this instruction manual. The EU-type examination certificate has to be observed. The special conditions must be adhered to! The ATEX directive and therefore the EU-type examination certificates are in general only applicable to the use of electrical apparatus operating at atmospheric conditions.

The use in ambient temperatures of > 60 °C was tested with regard to hot surfaces by the mentioned certification authority.

If the equipment is not used under atmospheric conditions, a reduction of the permissible minimum ignition energies may have to be taken into consideration.

Details of the correlation between the type of circuit connected, the maximum permissible ambient temperature, the surface temperature, and the effective internal reactance values can be found on the EC-type-examination certificate. **The maximum permissible ambient temperature of the data sheet must be noted, in addition, the lower of the two values must be maintained.**

Laws and/or regulations and standards governing the use or intended usage goal must be observed. The intrinsic safety is only assured in connection with an appropriate related apparatus and according to the proof of intrinsic safety. If the Ex-related marking is printed only on the supplied label, then this must be attached in the immediate vicinity of the sensor. The sticking surface for the label must be clean and free from grease. The attached label must be legible and indelible, including in the event of possible chemical corrosion. After opening the housing, you should check that the seal is in the correct position and is clean and intact before closing the housing again.

No changes can be made to apparatus, which are operated in hazardous areas. Repairs to these apparatus are not possible. After opening the housing, you should check that the seal is in the correct position and is clean and intact before closing the housing again.

The connecting parts of the sensor must be set up in such a way that degree of protection IP20, in accordance with IEC 60529, is achieved as a minimum.

When using the device in a temperature range of -60 °C to -20 °C, protect the sensor against the effects of impact by installing an additional enclosure. The information regarding the minimum ambient temperature for the sensor as provided in the datasheet must also be observed.

Avoid electrostatic charges that can cause electrostatic discharge when installing or operating the device. Information on electrostatic hazards can be found in the technical specification IEC/TS 60079-32-1. Electrostatic charges must be avoided on the mechanical housing components. Dangerous electrostatic charges on the mechanical housing components can be avoided by incorporating these in the equipotential bonding. Do not attach the nameplate provided in areas where electrostatic charge can build up.