

Inductive sensor
Monitoring Kit for Power Clamps
NI2-Q6.5-AP6-0.1-FS4.4X3/S304

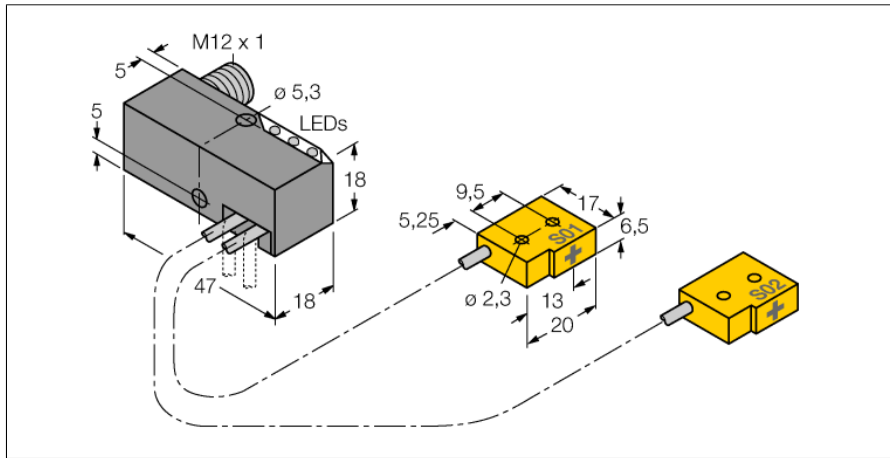

- Q6,5 power block with two connected sensors and LEDs
- Relocatable block 0°...90°, with cross drilling for flexible cable routing
- Plastic, PBT-GF20-V0
- Resistant to magnetic fields (weld resistant), for DC and AC fields
- 2 x NO contact, PNP output
- DC 4-wire, 10...30 VDC

Wiring Diagram

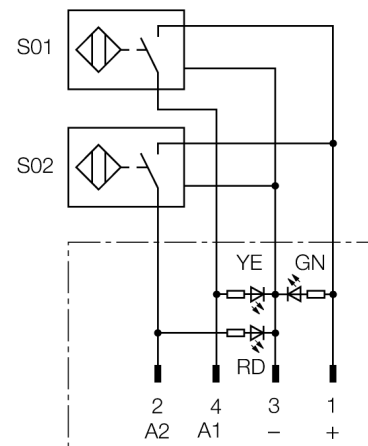

Functional principle

TURCK offers special monitoring kits, consisting of two miniature sensors, as a convenient solution for "Open/Closed" detection on pneumatic power clamps. This product line provides almost unlimited combination possibilities, comprising four different power blocks and over 40 different modular sensor types.

Type designation	NI2-Q6.5-AP6-0.1-FS4.4X3/S304
Ident no.	1650048
Rated switching distance S_n	2 mm
Mounting conditions	Non-flush
Secured operating distance	$\leq (0,81 \times S_n)$ mm
Correction factors	St37 = 1; Al = 0.7; stainless steel = 0.75; Ms = 0.45
Repeat accuracy	$\leq 2\%$ of full scale
Temperature drift	$\leq \pm 10\%$
Hysteresis	3...15 %
Ambient temperature	-25...+70 °C
Operating voltage	10...30 VDC
Residual ripple	$\leq 10\% U_{ss}$
DC rated operational current	≤ 150 mA
No-load current I_0	≤ 20 mA
Residual current	≤ 0.1 mA
Isolation test voltage	≤ 0.5 kV
Short-circuit protection	yes/ Cyclic
Voltage drop at I_n	≤ 1.8 V
Output function	4-wire, NO contact, PNP
Reverse polarity protection	Complete
Smallest operating current I_{min}	≥ 1 mA
Protection class	□
Switching frequency	0.03 kHz
Design	Monitoring kit for spanners, Q6.5
Dimensions	47 x 18 x 18 mm
Housing material	Metal, PBT-GF20-V0
Active area material	Plastic, PP GR-20
Electrical connection	Connector, M12 x 1
Cable quality	2 mm, Gray, Lif9Y-11Y, PUR, 0.1mm
Cable cross section	3 x 0.08 mm ²
Litz wire	40x0.05mm
Vibration resistance	55 Hz (1 mm)
Shock resistance	30 g (11 ms)
Protection class	IP67
MTTF	2283 years acc. to SN 29500 (Ed. 99) 40 °C
Power-on indication	LED green
Switching state	LED yellow / red
Included in delivery	Screw M5 x 25 DIN 912

**Inductive sensor
Monitoring Kit for Power Clamps
NI2-Q6.5-AP6-0.1-FS4.4X3/S304**

Mounting instructions/Description	minimum distances
Distance D	3 x B
Distance W	3 x Sn
Distance S	1.5 x B
Distance G	6 x Sn
Distance N	2 x Sn
Width active area B	6.5 mm

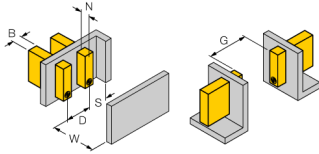

Please note, non-flush mounting of this sensor is obligatory.

The following conditions allow semi-flush mounting:

N1 = 0 mm and S1 = 1 mm or

N1 = 1 mm and S1 = 0 mm

These values apply for mounting in aluminium

N1 = 0 mm and S1 = 5 mm or

N1 = 5 mm and S1 = 0 mm

These values apply for mounting in St37.

**Inductive sensor
Monitoring Kit for Power Clamps
NI2-Q6.5-AP6-0.1-FS4.4X3/S304**

Wiring accessories

Type code	Ident no.	Description	
RKC4.4T-2/TEL	6625013	Connection cable, female M12, straight, 4-pin, cable length: 2 m, sheath material: PVC, black; cULus approval; other cable lengths and qualities available, see www.turck.com	