

# Inductive sensor NI20-K40SR-VN4X2

**TURCK**

Industrial  
Automation

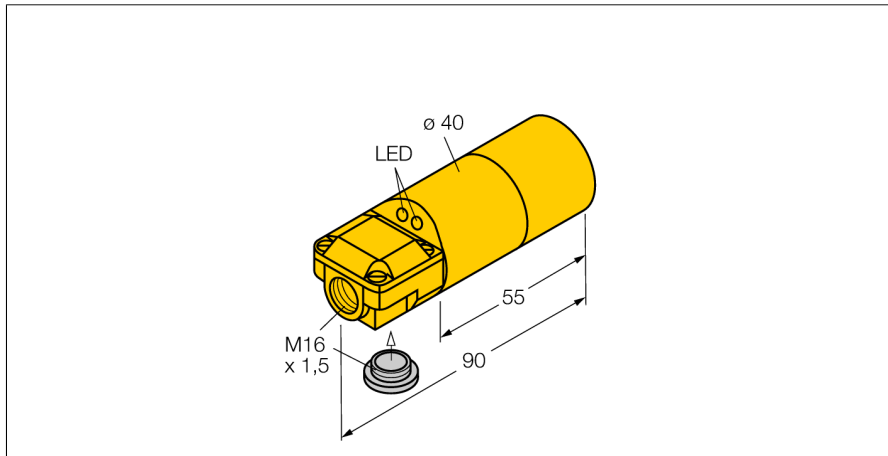

- 2 cable entries (axial, radial)
- Smooth barrel, Ø 40 mm
- Plastic, ABS
- DC 4-wire, 10...65 VDC
- Changeover contact, NPN output
- Terminal chamber

### Wiring Diagram

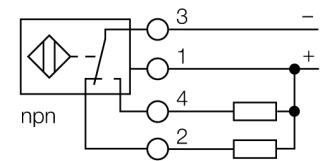

### Functional principle

Inductive sensors detect metal objects contactless and wear-free. For this, they use a high-frequency electromagnetic AC field that interacts with the target. Inductive sensors generate this field via an RLC circuit with a ferrite coil.

<b>Type designation</b>	NI20-K40SR-VN4X2
Ident no.	15756
<b>Rated switching distance <math>S_n</math></b>	20 mm
Mounting conditions	Non-flush
Secured operating distance	$\leq (0,81 \times S_n)$ mm
Correction factors	St37 = 1; Al = 0.3; stainless steel = 0.7; Ms = 0.4
Repeat accuracy	$\leq 2\%$ of full scale
Temperature drift	$\leq \pm 10\%$
Hysteresis	3...15 %
Ambient temperature	-25...+70 °C
<b>Operating voltage</b>	10...65 VDC
Residual ripple	$\leq 10\%$ $U_{ss}$
DC rated operational current	$\leq 200$ mA
No-load current $I_0$	$\leq 15$ mA
Residual current	$\leq 0.1$ mA
Isolation test voltage	$\leq 0.5$ kV
Short-circuit protection	yes/ Cyclic
Voltage drop at $I_0$	$\leq 1.8$ V
Wire breakage/Reverse polarity protection	yes/ Complete
Output function	4-wire, Complementary contact, NPN
Reverse polarity protection	Complete
Switching frequency	0.1 kHz
<b>Design</b>	Smooth barrel, 40 mm
Dimensions	90 mm
Housing material	Plastic, ABS
Active area material	Plastic, ABS
Electrical connection	Terminal chamber
Clamping ability	$\leq 2.5$ mm <sup>2</sup>
Vibration resistance	55 Hz (1 mm)
Shock resistance	30 g (11 ms)
Protection class	IP67
MTTF	2283 years acc. to SN 29500 (Ed. 99) 40 °C
<b>Power-on indication</b>	LED green
Switching state	LED yellow
Included in delivery	BS40, cable gland, blanking plug

**Inductive sensor  
NI20-K40SR-VN4X2**

<b>Distance D</b>	3 x B
Distance W	3 x Sn
Distance T	3 x B
Distance S	1.5 x B
Distance G	6 x Sn
Distance N	2 x Sn
<b>Diameter active area B</b>	Ø 40 mm

