



### Model Number

**NBB7-F10-E2-V1**

### Features

- 7 mm flush
- 3-wire DC

### Accessories

#### V1-W

Female connector, M12, 4-pin, field attachable

#### V1-G

Female connector, M12, 4-pin, field attachable

#### V1-G-2M-PUR

Female cordset, M12, 4-pin, PUR cable

#### V1-W-2M-PUR

Female cordset, M12, 4-pin, PUR cable

## Technical Data

### General specifications

Switching function		Normally open (NO)
Output type		PNP
Rated operating distance	$s_n$	7 mm
Installation		flush
Output polarity		DC
Assured operating distance	$s_a$	0 ... 5.67 mm
Reduction factor $r_{AI}$		0.3
Reduction factor $r_{CU}$		0.2
Reduction factor $r_{304}$		0.6
Output type		3-wire

### Nominal ratings

Operating voltage	$U_B$	10 ... 30 V DC
Switching frequency	$f$	0 ... 500 Hz
Hysteresis	$H$	typ. 5%
Reverse polarity protection		reverse polarity protected
Short-circuit protection		pulsing
Voltage drop	$U_d$	$\leq 3$ V
Operating current	$I_L$	0 ... 100 mA
Off-state current	$I_r$	0 ... 0.5 mA typ. 0.1 $\mu$ A at 25 °C
No-load supply current	$I_0$	$\leq 15$ mA
Switching state indicator		LED, yellow

### Ambient conditions

Ambient temperature		-25 ... 70 °C (-13 ... 158 °F)
---------------------	--	--------------------------------

### Mechanical specifications

Connection type		Connector M12 x 1, 4-pin
Housing material		PBT
Sensing face		PBT
Degree of protection		IP67

### Compliance with standards and directives

Standard conformity		
Standards		EN 60947-5-2:2007 EN 60947-5-2/A1:2012 IEC 60947-5-2:2007 IEC 60947-5-2 AMD 1:2012

### Approvals and certificates

UL approval		cULus Listed, General Purpose
CCC approval		CCC approval / marking not required for products rated $\leq 36$ V

## Dimensions

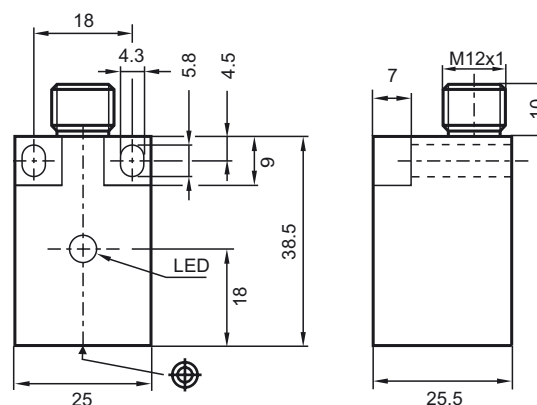

**Electrical Connection**



**Pinout**



Wire colors in accordance with EN 60947-5-2

1		BN	(brown)
2		WH	(white)
3		BU	(blue)
4		BK	(black)