

MK5139

MKT3020BBPKG/A/0.3M/ZH/US

Magnetic sensors, cylinder sensors

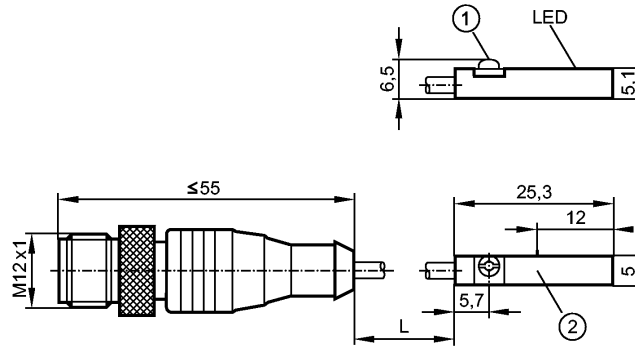

- 1: Fastening clamp
- 2: sensing face



Product characteristics

cylinder sensor with AMR cell

Plastic housing for T-slot cylinders

Cable with connector

[f] flush mountable

Magnetic sensitivity 2 mT

Travel speed > 10 m/s

Electrical data

Electrical design	DC PNP
Operating voltage [V]	10...30 DC; cULus - Class 2 source required
Current consumption [mA]	< 10
Protection class	III
Reverse polarity protection	yes

Outputs

Output function	normally open
Voltage drop [V]	< 2.5
Current rating [mA]	100
Short-circuit protection	yes
Overload protection	yes
Switching frequency [Hz]	6000

Monitoring range

Magnetic sensitivity [mT]	2
Travel speed [m/s]	> 10

Accuracy / deviations

Hysteresis [mm]	< 1
Repeatability [mm]	< 0.2

Reaction times

Power-on delay time [ms]	< 30
--------------------------	------

Environment

Ambient temperature [°C]	-25...85
Protection	IP 65 / IP 67

Tests / approvals

EMC	EN 61000-4-2 ESD:	- CD / 8 kV AD
-----	-------------------	----------------



MK5139

MKT3020BBPKG/A/0.3M/ZH/US

Magnetic sensors, cylinder sensors

	EN 61000-4-3 HF radiated:	10 V/m
	EN 61000-4-4 Burst:	2 kV
	EN 61000-4-6 HF conducted:	10 V
	EN 55011:	class B
MTTF	[Years]	2064
UL approval number		C003

Mechanical data

Mounting		flush mountable
Housing materials		housing: PA (polyamide); Fastening clamp: stainless steel
Weight	[kg]	0.021

Displays / operating elements

Output status indication	LED	yellow
--------------------------	-----	--------

Electrical connection

Connection		PUR cable / 0.3 m; with M12 connector, with turnable coupling ring
------------	--	--

Wiring

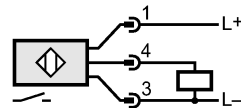

Accessories

Accessories (included)		rubber placeholder; cable clip
------------------------	--	--------------------------------

Remarks

Remarks		Clamping screw with combined slot/hexagon socket head AF 1.5
---------	--	--

Pack quantity	[piece]	1
---------------	---------	---