

no longer available - archive entry replaced by: MK5311

efector120

MK5056



MKN3000-BPKG/0.3M AS-510-TPS

Magnetic sensors, cylinder sensors

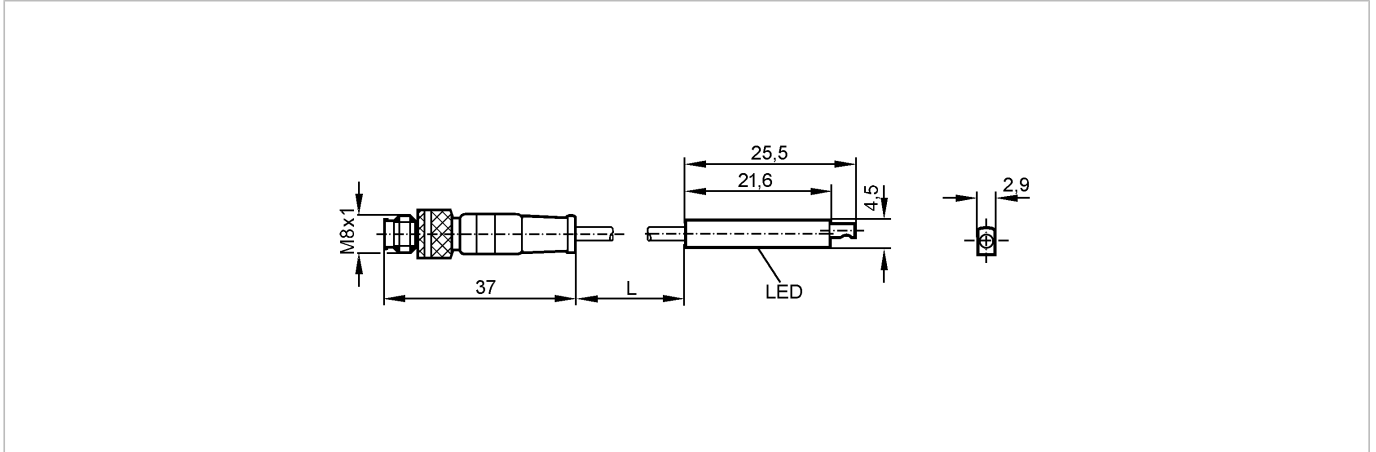

Product characteristics

Cylinder sensor

Plastic housing for C-slot cylinders

Cable with connector

Magnetic sensitivity 2.5 mT

Travel speed max. 5 m/s

Active face at the front

Electrical data

Electrical design

DC PNP

Operating voltage [V]

10...30 DC

Current consumption [mA]

< 12

Reverse polarity protection

yes

Outputs

Output function

normally open

Voltage drop [V]

< 3.1

Current rating [mA]

100

Short-circuit protection

yes (non-latching)

Overload protection

yes

Switching frequency [Hz]

10000

Monitoring range

Magnetic sensitivity [mT]

2.5

Travel speed [m/s]

max. 5

Accuracy / deviations

Hysteresis [mm]

1...2

Repeatability [mm]

0.1

Reaction times

Power-on delay time [ms]

< 1

Environment

Ambient temperature [°C]

-25...70

Protection

IP 67

Tests / approvals

EMC

EN 60947-5-2

Shock / vibration resistance

30 g (11 ms) / 10-55 Hz (1 mm)

Mechanical data

sensing face

Active face at the front

Housing materials

LCP

Weight [kg]

0.01

MK5056 - Cylinder sensor - eclass: 27270104 / 27-27-01-04

Displays / operating elements

Output status indication LED | yellow

Electrical connection

Connection | PUR cable / 0.3 m; with M8 connector, with turnable coupling ring

Wiring

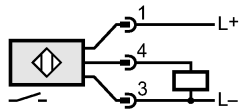
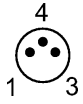

Remarks

Pack quantity [piece] | 1

ifm efector, inc. • 1100 Atwater Drive • Malvern • PA 19355 — We reserve the right to make technical alterations without prior notice. — US — MK5056 — 06.03.2003
no longer available - archive entry replaced by: MK5311