



Model Number

LS230-DA

Optical data coupler, 230 m detection range, infrared light, RS232/RS422 interface, data rate of up to 19.2 bit/s, terminal compartment

Features

- 3 interfaces in a device can be selected via DIP switches
 - RS 232
 - RS 422
 - CL
- High detection ranges achievable
- Easy adjustment by integrated alignment LED and finder scope
- Band display for signal strength
- Sturdy aluminum housing

Dimensions

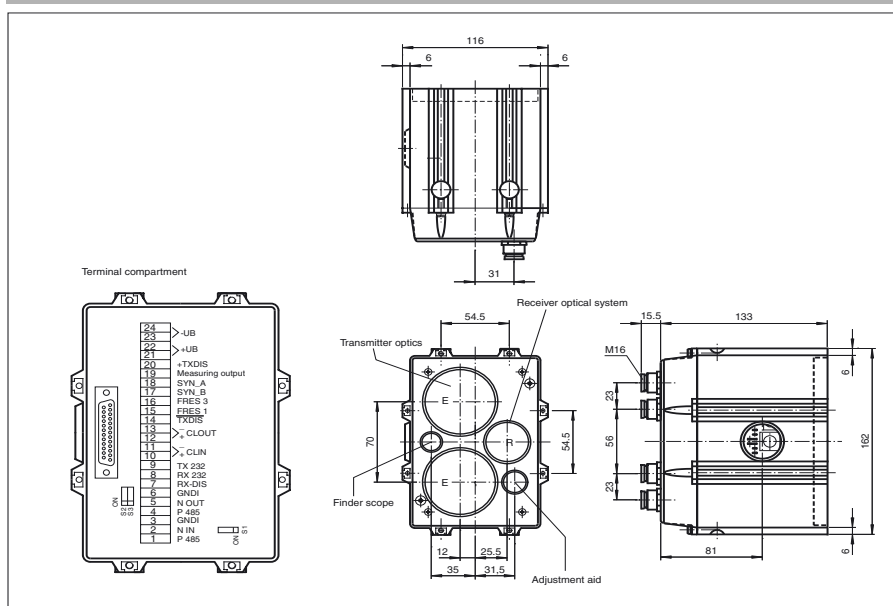

Technical data

General specifications

Effective detection range	0 ... 230 m
Threshold detection range	340 m
Light source	IREDD
Light type	modulated infrared light
Approvals	CE
Alignment aid	Telescopic sight, frontal red LED flashing, off with Signal > sufficient stability control
Transmission mode	FSK
Response delay	40 μs
Diameter of the light spot	8000 mm at a distance of 230 m
Angle of divergence	emitter 2 ° , receiver 5 °
Ambient light limit	3000 Lux

Indicators/operating means

Data flow display	LED green: emitter LED yellow: receiver
Function display	LED band display 3-colour, LED red: single switching point LEDs yellow, 4-stage: sufficient switching point LED green: 3-fold switching point
Controls	8-fold DIP-switch for selection of transmission frequency and interface in the terminal compartment

Electrical specifications

Operating voltage	U_B	24 V DC ± 25 %
No-load supply current	I_0	250 mA
Data sampling blanking		emitter deactivation for + U_B , emitter deactivation TTL-compatible, receiver deactivation TTL-compatible
Data rate		0 ... 19.2 kBit/s
Operation frequency		F1 = 83 kHz , F2 = 118 kHz

Interface

Interface type	RS 232, RS 422, CL20 mA active/passive switchable
----------------	---

Output

Pre-fault indication output	2 PNP-outputs, short-circuit protected, 30 V DC 0.1 A activated for single or sufficient stability control
Measurement output	2.5 ... 6 V DC, max. 10 mA , single stability control 3.5 V , sufficient stability control 5 V

Standard conformity

Standards	EN 60947-5-2
-----------	--------------

Ambient conditions

Ambient temperature	-20 ... 50 °C (-4 ... 122 °F)
Storage temperature	-20 ... 75 °C (-4 ... 167 °F)

Mechanical specifications

Protection degree	IP65
Connection	4 x M16 cable glands , spring terminals in the terminal compartment
Material	
Housing	aluminum
Optical face	plastic lenses, glass windows
Mass	1600 g

Curves / Diagrams

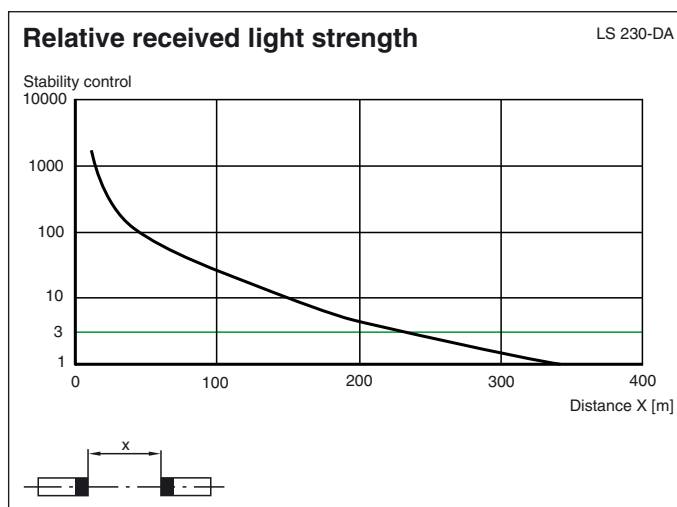
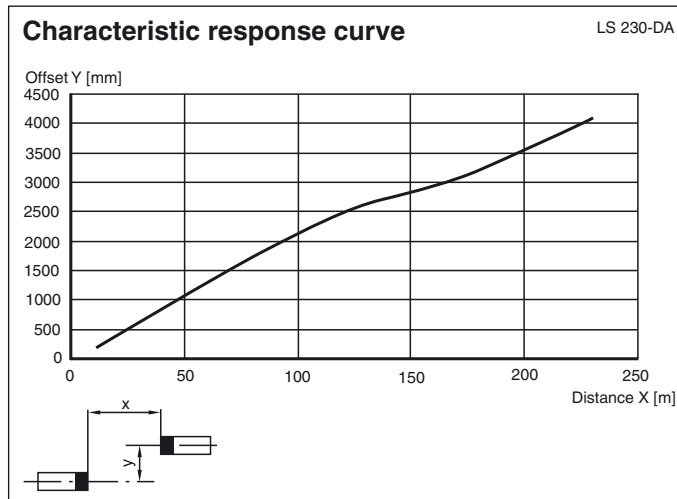

Function

The LS230-DA is a device for serial data transfer for data rates up to 19.2 kbaud and sensing ranges up to 230 m. Devices with option /135 have a sensing range up to 350 m. The device can be used problem-free with data rates and effective operating distances under these values. The transfer takes place without protocols. If two full duplex channels are installed parallel, chose one infrared channel and the other as a red transmission light.

Data transfer

To avoid mutual interference of both transfer channels, the transmitter and receiver of each device are used with different center frequency F1/F2. The frequency is set with DIP switch S1.

S1: ON = Transmitter F1, Receiver F2
 OFF = Transmitter F2, Receiver F1

Function display/function reserve

The red LED of the band display lights if the level of the received signal is sufficient for error-free transfer. The transfer is enabled from this level. The green LED lights when sufficient function reserve is displayed.

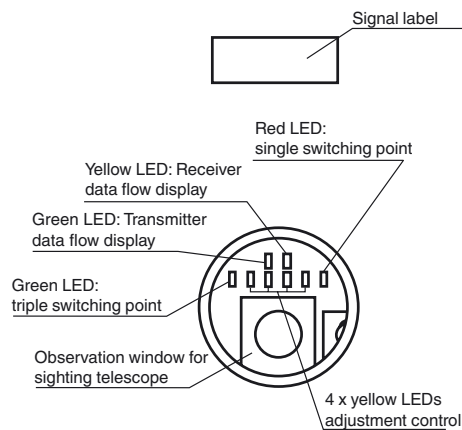

Interface

The LS 230-DA contains a standard interface module for serial transfer. The output interfaces are controlled simultaneously. To select the input interface, the corresponding DIP switch S2-S4 is set to ON.

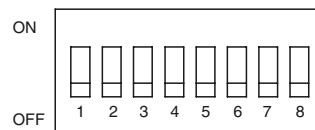

20-mA current loop (CL)

S2: ON = 20 mA current loop

Serial current interface with defined current level (Low = 0 mA, High = 20 mA) and for connection to a remote station. It transfers data along leads up to 1 km long. With the LS-230-DA, the 20 mA interfaces can be operated in active or passive mode. This is set with DIP switches S7 and S8.

The interface that stores the current is designated as active. Only one of the two communication partners can be active (optical data carrier or control). With the help of DIP switches S7 and S8, the LS230-DA can be operated with both a passive and active CL 20 mA interface. It is also possible to operate one interface active and the other passive.

Example:

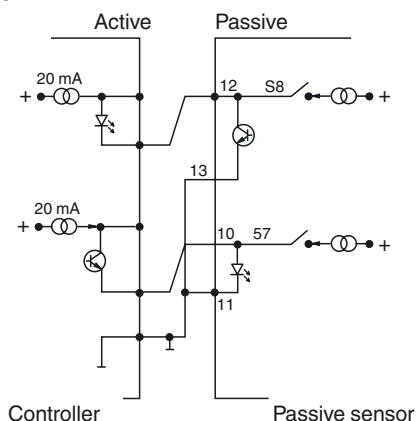

S7 ON = input interface active, 20 mA current loop
OFF = input interface passive

S8: ON = input interface active, 20 mA current loop
OFF = output interface passive

RS 232

S3 ON = RS 232

Serial voltage interface (one or two data lines) with levels usual in PC peripherals (Low = 3 V up to 15 V, High = -3 V up to -15 V), relevant to a common mass. It is designed for distances up to 20 m sensing range and connection to a remote station.

RS 422

S4 ON = RS 422

Serial voltage interface for fast transfer over large distances (up to 1.5 km). The logic statuses are defined via a voltage comparison.

Caution! Only one of the S2 – S4 switches should be switched on!

Data signal negation is possible with a further switch for special applications. The data volumes are shown for the transfer and receive status are shown with separate LEDs.

S5 ON = input signal of the transmitter inverted
OFF = input signal of the transmitter not inverted

S6 ON = output signal of the receiver inverted
OFF = output signal of the receiver not inverted

Release date: 2012-12-19 17:05 Date of issue: 2013-01-09 418626_eng.xml

With light beam interruption, the sensor goes into pause status. With the transfer system, this is logically high, i.e. for RS 232 - 3 V to 15 V, for RS 422 the level difference is under 3 V ($A \leq B$) and for die CL interface a conductive 20 mA current loop.

All described settings are made on the DIP switches which are found on the interface print. The switches are visible after removing the enclosure cover.

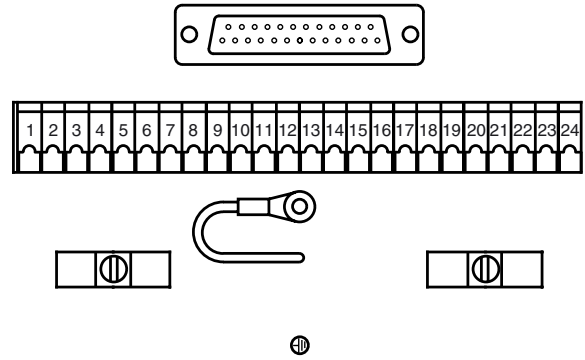

View of enclosure without cover:

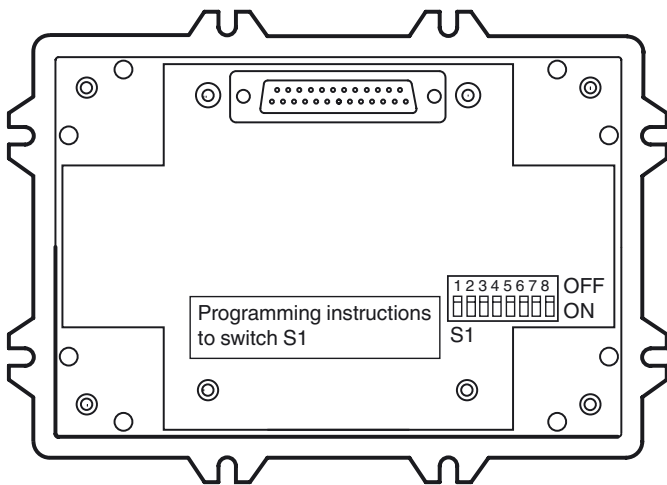

Mounting bracket:

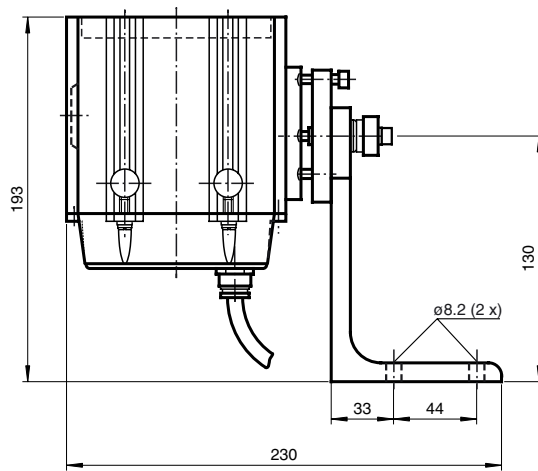

Release date: 2012-12-19 17:05 Date of issue: 2013-01-09 418626_eng.xml