



Model Number

KS11/KSE11/59/102/115

Thru-beam sensor
with 2 m fixed cable

Features

- Large detection range, up to 250 mm
- Very small housing
- Complete device, no amplifier needed
- Voltage range 10 V ... 30 V DC, output current 100 mA short-circuit protected
- Optical parts made of glass, easy cleaning
- Degree of protection IP67

Dimensions

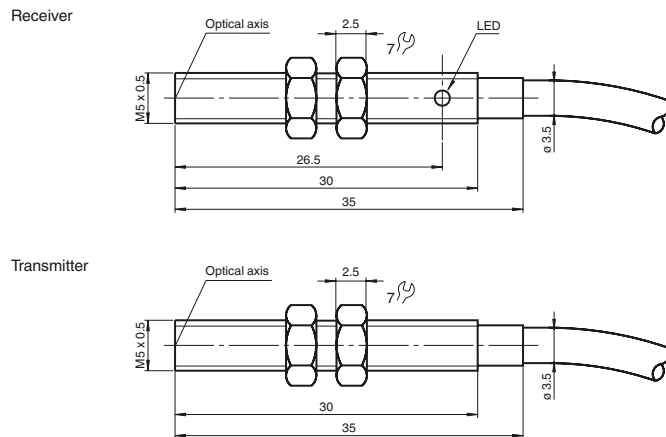

Electrical connection

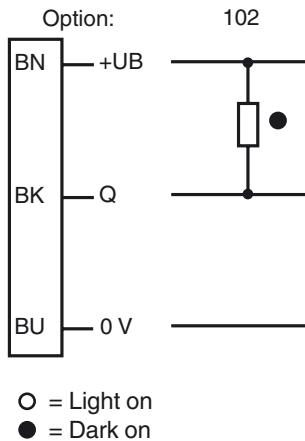

Release date: 2014-10-02 14:35 Date of issue: 2014-10-02 118350_eng.xml

Refer to "General Notes Relating to Pepperl+Fuchs Product Information".

Pepperl+Fuchs Group
www.pepperl-fuchs.com

USA: +1 330 486 0001
fa-info@us.pepperl-fuchs.com

Germany: +49 621 776 4411
fa-info@de.pepperl-fuchs.com

Singapore: +65 6779 9091
fa-info@sg.pepperl-fuchs.com

Technical data**General specifications**

Effective detection range	0 ... 250 mm
Light source	LED
Light type	modulated infrared light
Optical face	frontal
Ambient light limit	10000 Lux

Indicators/operating means

Function indicator	switching state, LED yellow
--------------------	-----------------------------

Electrical specifications

Operating voltage	U_B	10 ... 30 V DC
Ripple		10 %
No-load supply current	I_0	≤ 15 mA (device)
Time delay before availability	t_v	≤ 20 ms

Input

Test input	inactive: ≤ 4 V; active: ≤ 8 V or unwired (emitter)
------------	---

Output

Switching type	dark on	
Signal output	1 switch output NPN	
Switching voltage	max. 30 V DC	
Switching current	max. 100 mA	
Switching frequency	f	≤ 250 Hz
Response time		≤ 3 ms

Ambient conditions

Ambient temperature	0 ... 55 °C (32 ... 131 °F)
---------------------	-----------------------------

Mechanical specifications

Degree of protection	IP67
Connection	2 m fixed cable ; 3 x 0.14 mm ² , PVC
Material	
Housing	Stainless steel 1.4305 / AISI 303
Optical face	Scratch resistant mineral glass lens
Mass	76 g (device)

Compliance with standards and directives

Standard conformity	
Product standard	EN 60947-5-2:2007 IEC 60947-5-2:2007

Additional accessories can be found in the Internet.

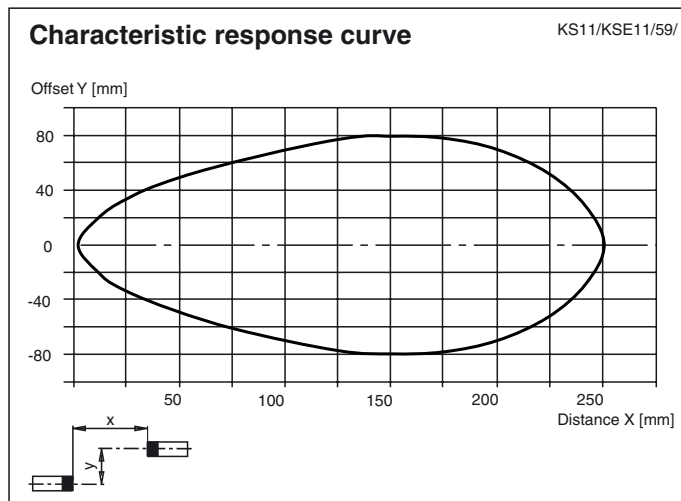
Curves/Diagrams

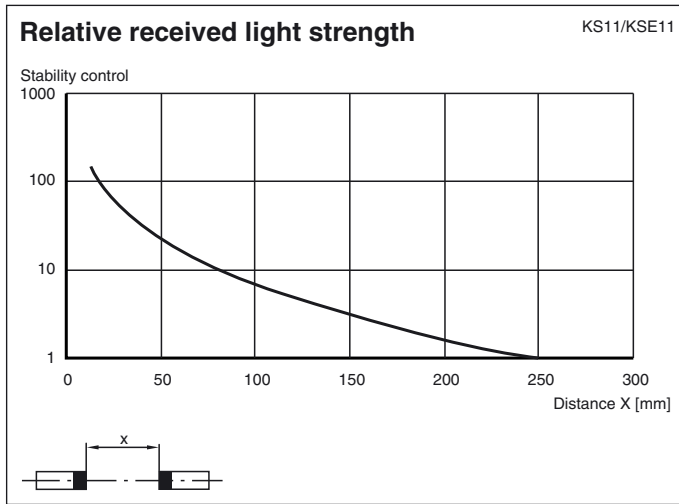

Release date: 2014-10-02 14:35 Date of issue: 2014-10-02 118350_eng.xml

Refer to "General Notes Relating to Pepperl+Fuchs Product Information".

Pepperl+Fuchs Group
www.pepperl-fuchs.com

USA: +1 330 486 0001
fa-info@us.pepperl-fuchs.com

Germany: +49 621 776 4411
fa-info@de.pepperl-fuchs.com

Singapore: +65 6779 9091
fa-info@sg.pepperl-fuchs.com