

IM5117

IMC3040-BPKG/US-100-DPS

Inductive sensors

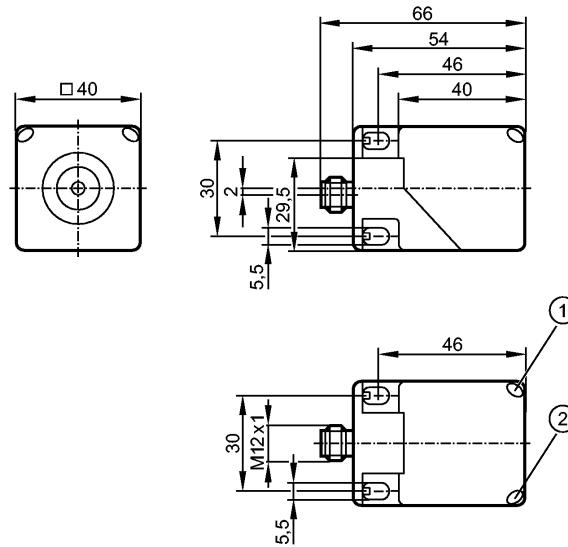

- 1: LED yellow
- 2: LED green



Product characteristics

Inductive sensor
Rectangular, plastics
Quick disconnect
5 positions of the sensing face selectable
Sensing range 40 mm; [nf] non-flush mountable

Electrical data

Electrical design	DC PNP
Operating voltage [V]	10...36 DC; cULus - Class 2 source required
Current consumption [mA]	< 20
Protection class	II
Reverse polarity protection	yes

Outputs

Output function	normally open
Voltage drop [V]	< 2.5
Current rating [mA]	200
Short-circuit protection	yes (non-latching)
Overload protection	yes
Switching frequency [Hz]	60

Monitoring range

Sensing range [mm]	40
Operating distance [mm]	0...32.4

Accuracy / deviations

Correction factors	mild steel = 1 / stainless steel approx. 0.7 / brass approx. 0.4 / aluminium approx. 0.4 / copper approx. 0.3
Hysteresis [% of Sr]	1...20

Environment

Ambient temperature [°C]	-25...70
Protection	IP 67

IM5117

IMC3040-BPKG/US-100-DPS

Inductive sensors

Tests / approvals

EMC	EN 61000-4-2 ESD:	8 kV CD / 6 kV AD
	EN 61000-4-3 HF radiated:	10 V/m
	EN 61000-4-4 Burst:	2 kV
	EN 61000-4-5 Surge:	0.5 kV (line to line, Ri: 20hm)
	EN 61000-4-6 HF conducted:	10 V
	EN 55011:	class B

MTTF	[Years]	1494
------	---------	------

Mechanical data

Mounting	non-flush mountable
Housing materials	PA (polyamide)
Weight	[kg] 0.15

Displays / operating elements

Output status indication	LED	yellow
Power	LED	green

Electrical connection

Connection	M12 connector; rotatable, locking
------------	-----------------------------------

Wiring

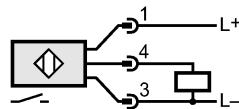

Remarks

Pack quantity	[piece]	1
---------------	---------	---