

no longer available - archive entry

efector100

I10263



IIA2015-ABOA/SL/LS-300BL/RT

Inductive sensors

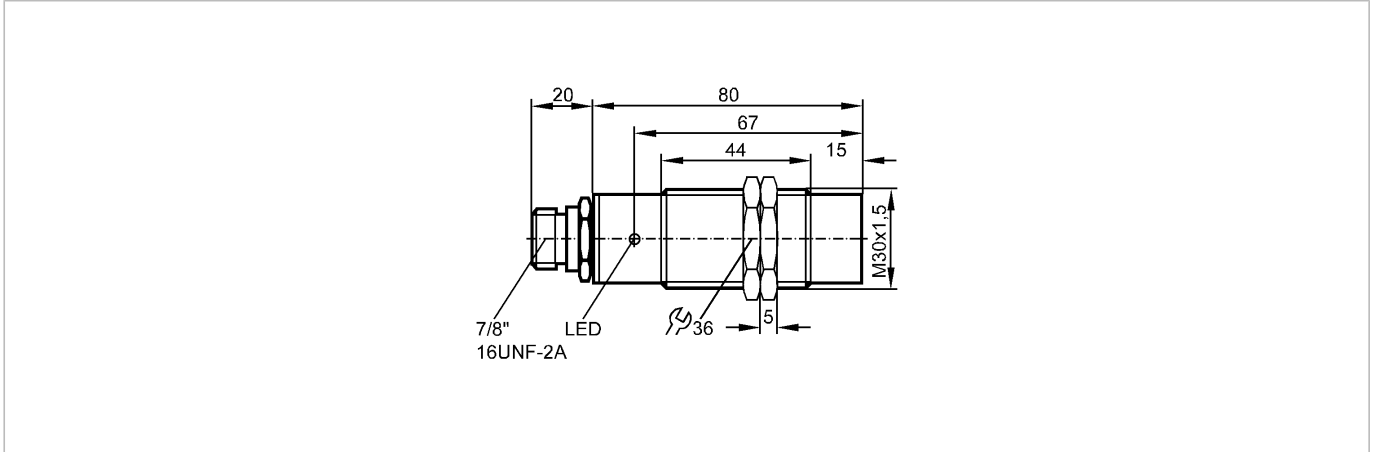

Product characteristics

Inductive sensor

Metal thread M30 x 1.5

Quick disconnect

Sensing range 15 mm; [nf] non-flush mountable

Electrical data

Electrical design	AC/DC
Operating voltage [V]	20...250 AC/DC
Protection class	I
Reverse polarity protection	yes
Outputs	
Output function	normally open
Voltage drop [V]	< 6.5 AC / < 6 DC
Minimum load current [mA]	5
Leakage current [mA]	< 2.5 (250 V AC) / < 1.3 (110 V AC) / < 0.8 (24 V DC)
Current rating	
- Current rating (continuous) [mA]	250 AC / 100 DC; 350 AC (...50 °C)
- Current rating (peak) [mA]	î: 2.2 A (20 ms / 0.5 Hz)
Short-circuit proof	no
Overload protection	yes
Switching frequency [Hz]	25 AC / 50 DC
Monitoring range	
Sensing range [mm]	15
Real sensing range (Sr) [mm]	15 ± 10 %
Operating distance [mm]	0...12.1
Accuracy / deviations	
Correction factors	mild steel = 1 / stainless steel approx. 0.7 / brass approx. 0.5 / aluminium approx. 0.4 / copper approx. 0.3
Hysteresis [% of Sr]	3...15
Switch-point drift [% of Sr]	-10...10
Environment	
Ambient temperature [°C]	-25...80
Protection	IP 67
Tests / approvals	
EMC	EN 60947-5-2 EN 55011: class B
MTTF [Years]	607

II0263 - Inductive sensor - eclass: 27270101 / 27-27-01-01

Mechanical data	
Mounting	non-flush mountable
Housing materials	brass white bronze coated; PBT (Pocan)
Weight [kg]	0.202
Displays / operating elements	
Output status indication LED	red
Electrical connection	
Connection	7/8" connector

Wiring

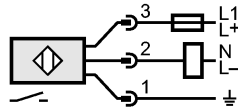

Note: miniature fuse to IEC60127-2 sheet 1,
 ≤ 2 A (fast acting)

Accessories	
Accessories (included)	2 lock nuts
Remarks	
Remarks	Recommendation: check the unit for reliable function after a short circuit.
Pack quantity [piece]	1

ifm efector, inc. • 1100 Atwater Drive • Malvern • PA 19355 — We reserve the right to make technical alterations without prior notice. — US — II0263 — 06.03.2003
 no longer available - archive entry