

IGT205

IGKC008BASKG/M/V4A/US-104-DRS

Inductive sensors

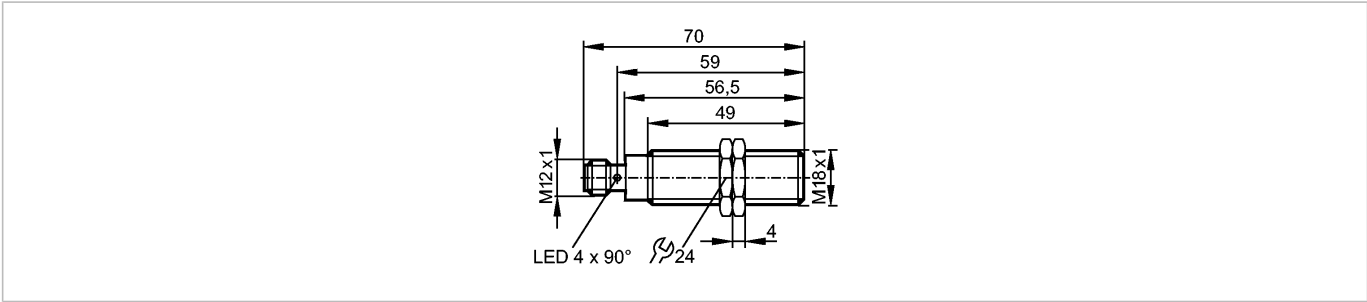

Product characteristics

Inductive sensor
Metal thread M18 x 1
Quick disconnect
Operation as 3-wire or 2-wire possible
Increased sensing range
Optical setting aid (2 LED)
gold-plated contacts
Sensing range 8 mm; [f] flush mountable

Electrical data

Electrical design	3-wire DC PNP; 2-wire DC PNP/NPN
Operating voltage [V]	10...36 DC
Protection class	II
Reverse polarity protection	yes

Outputs

Output function	normally open
Voltage drop [V]	< 2.8
Minimum load current [mA]	2; only in 2-wire operation
Leakage current [mA]	< 0.5; only in 2-wire operation
Current rating [mA]	100
Short-circuit protection	yes (non-latching)
Overload protection	yes
Switching frequency [Hz]	400

Monitoring range

Sensing range [mm]	8
Operating distance [mm]	0...6.48

Accuracy / deviations

Correction factors	mild steel = 1 / stainless steel approx. 0.8 / brass approx. 0.5 / aluminium approx. 0.4 / copper approx. 0.3
Hysteresis [% of Sr]	1...20

Environment

Ambient temperature [°C]	0...100
Protection	IP 68 / IP 69K; "COP"

Tests / approvals

EMC	EN 61000-4-2 ESD: 4 kV CD / 8 kV AD
	EN 61000-4-3 HF radiated: 10 V/m
	EN 61000-4-4 Burst: 2 kV

IGT205

IGKC008BASKG/M/V4A/US-104-DRS

Inductive sensors

	EN 61000-4-5 Surge:	0.5 kV (line to line, Ri: 20hm)
	EN 61000-4-6 HF conducted:	10 V
	EN 55011:	class B
MTTF	[Years]	1418

Mechanical data

Mounting	flush mountable
Housing materials	threaded sleeve: stainless steel (316L); active face: PEEK (polyether ether ketone); lock nuts: high-grade stainless steel
Weight	[kg] 0.056

Displays / operating elements

Output status indication	LED	yellow (4 x 90°)
Setting aid	LED	red

Electrical connection

Connection	M12 connector; gold-plated contacts
------------	-------------------------------------

Wiring

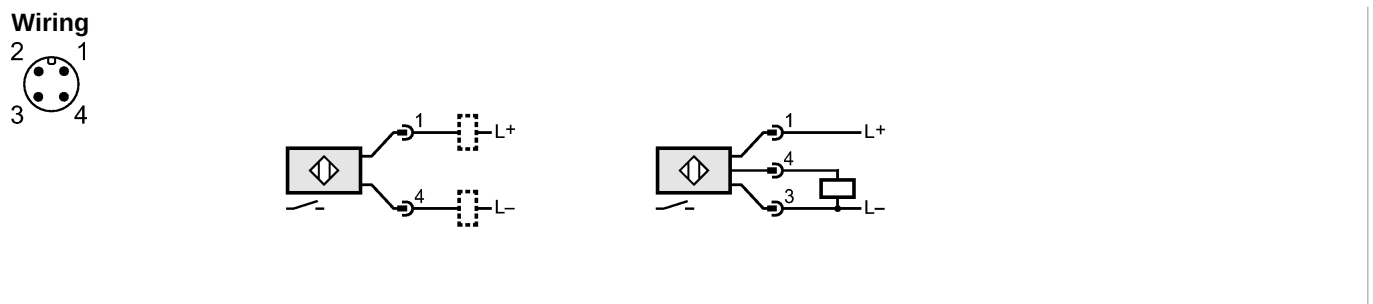

Accessories

Accessories (included)	2 lock nuts
------------------------	-------------

Remarks

Pack quantity	[piece]	1
---------------	---------	---