



### Model Number

**FLT-8-HW-2800-50/25/31**

Area scanner  
with connector, Binder series 581, 5-pin

### Features

- Area scanner with long detection range for detecting people and objects
- Version with Background evaluation
- Reliable detection, including of difficult objects, through background evaluation
- Possible detection range down to 0 m
- Version with detection area 50 mm x 500 mm
- Light on version

### Product information

The FLT-8 series active infra-red area scanners detect people and objects located within a defined sensing field, regardless of background and whether or not they are moving. The sensors generate a clearly defined spatial sensing field, which can be mechanically adjusted. This sensing field is comprised of three or four individual light beams.

### Dimensions

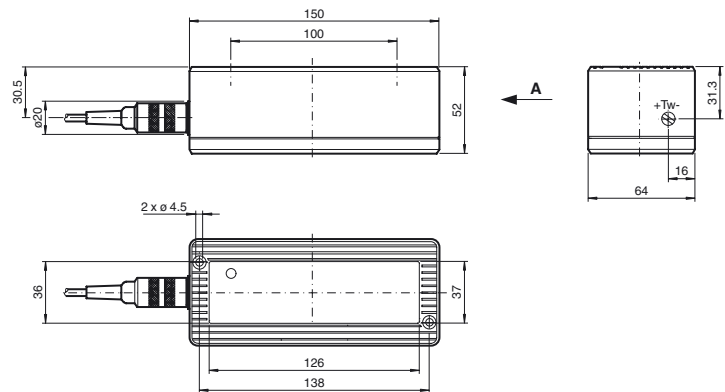

### Electrical connection

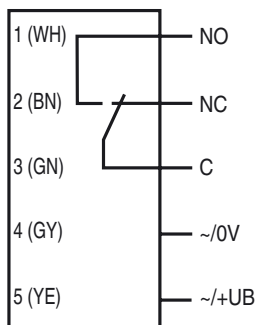

### Indicators/operating means

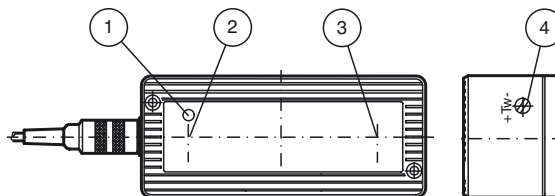

1	Functional display	red
2	Emitter	
3	Receiver	
4	Detection range adjuster	

**Technical data****General specifications**

Detection field	50 mm x 500 mm at 2000 mm sensor range
Detection range min.	0 ... 1200 mm
Detection range max.	0 ... 2800 mm
Light source	3 x IRED
Light type	modulated infrared light
Light spot representation	43 mm x 43 mm at 2000 mm
Marking	CE
Operating mode	Background evaluation

**Functional safety related parameters**

MTTF <sub>d</sub>	470 a
Mission Time (T <sub>M</sub> )	20 a
Diagnostic Coverage (DC)	0 %

**Indicators/operating means**

Function indicator	LED red
Control elements	Detection range adjuster

**Electrical specifications**

Operating voltage	U <sub>B</sub>	15 ... 48 V AC/DC
No-load supply current	I <sub>0</sub>	100 mA
Power consumption	P <sub>0</sub>	2.5 W

**Output**

Switching type	light on
Signal output	Relay, 1 alternator
Switching voltage	48 V AC/DC
Switching current	≤ 2 A
Switching power	500 VA
Response time	100 ms

**Ambient conditions**

Ambient temperature	-20 ... 60 °C (-4 ... 140 °F)
Storage temperature	-20 ... 75 °C (-4 ... 167 °F)

**Mechanical specifications**

Mounting height	max. 2800 mm
Degree of protection	IP65
Connection	Connector, Binder series 581, 5-pin
Material	
Housing	Novodur black
Optical face	Glass, red
Mass	320 g

**General information**

Scope of delivery	2 m Connecting cable
-------------------	----------------------

**Compliance with standards and directives**

Directive conformity	
EMC Directive 2004/108/EC	EN 60947-5-2:2007 + A1:2012
Standard conformity	
Product standard	EN 60947-5-2:2007 + A1:2012 IEC 60947-5-2:2007 + A1:2012
Emitted interference	EN 61000-6-3
Standards	EN 61000-6-2 without EN 61000-4-5, EN 61000-4-11

**Typical applications**

- Protection mechanism for closing edges on automatic doors and gates
- Monitoring hazardous areas, such as crushing or shearing edges
- Anti-collision protection on automated guided vehicles
- Presence checks for people

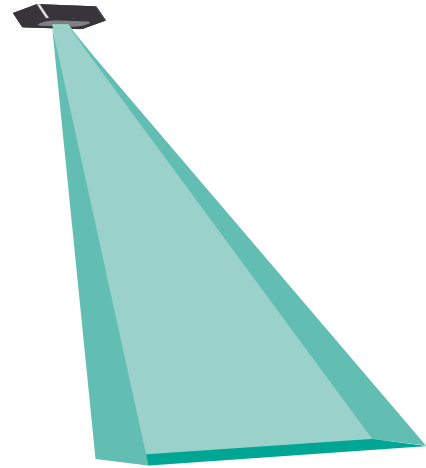
**Detection area****Accessories****Montageplatte FLT**

Mounting plate for FLT-8 series sensors

**FLT-50-AR**

alignment aid for FLT...-50

Other suitable accessories can be found at [www.pepperl-fuchs.com](http://www.pepperl-fuchs.com)

## Curves/Diagrams

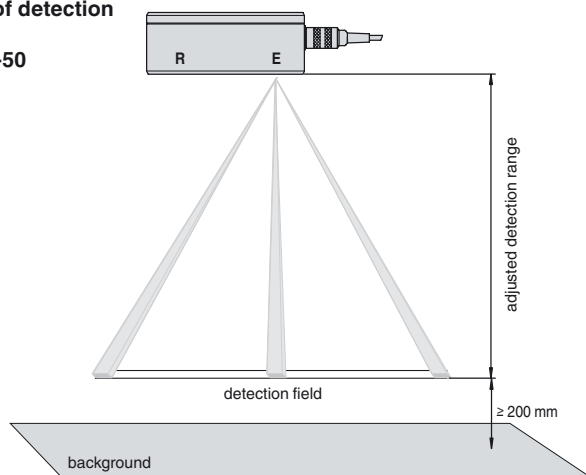
Size of detection field  
FLT...-50

Detection field size versus adjusted detection range:

detect. field	detection field size	spot size
1500 mm	380 mm x 38 mm	30 mm x 30 mm
1800 mm	450 mm x 50 mm	35 mm x 35 mm
2000 mm	500 mm x 50 mm	43 mm x 43 mm
2500 mm	610 mm x 61 mm	57 mm x 57 mm
2800 mm	685 mm x 68 mm	64 mm x 64 mm

## Operating principle

The FLT-8-HW serves to detect people and objects that appear in the detection range of the device. It reacts if at least one of the light beams connects with the object to be detected. The device functions as a sensor with background evaluation. In addition to the normal scenario—activation as soon as an object moves into the foreground—the sensor requires a signal from the background, which acts as a type of reflector. Compared to normal background suppression, this process offers significant advantages:

- Reliable: Even reflective objects are detected, as the sensor does not receive a signal from the background.
- Tamperproof: Partial or complete covering of the optical area is detected  
--> output is permanently set
- Fail-safe: Emitter failure message is sent if one of the emitters fails  
--> output is permanently set

When setting the detection range, ensure that the device is always aligned with a background. The detection range limit should be at least 200 mm from the background.

If the background (floor, wall) is permanently or occasionally reflective and shiny, due to moisture for example, the sensor must be mounted in such a manner that it is rotated through at least 5° along its longitudinal axis to prevent a mirror effect (figure).

Multiple sensors can be arranged in such a way that their detection fields adjoin one another or overlap, without resulting in faulty circuits.

The function of the sensor is indicated by a red LED, which is visible through the front panel.

