

no longer available - archive entry replaced by: EBC016

**ecomat 400**

E11017



ZDO4H059MSS0005H11

Connection technology

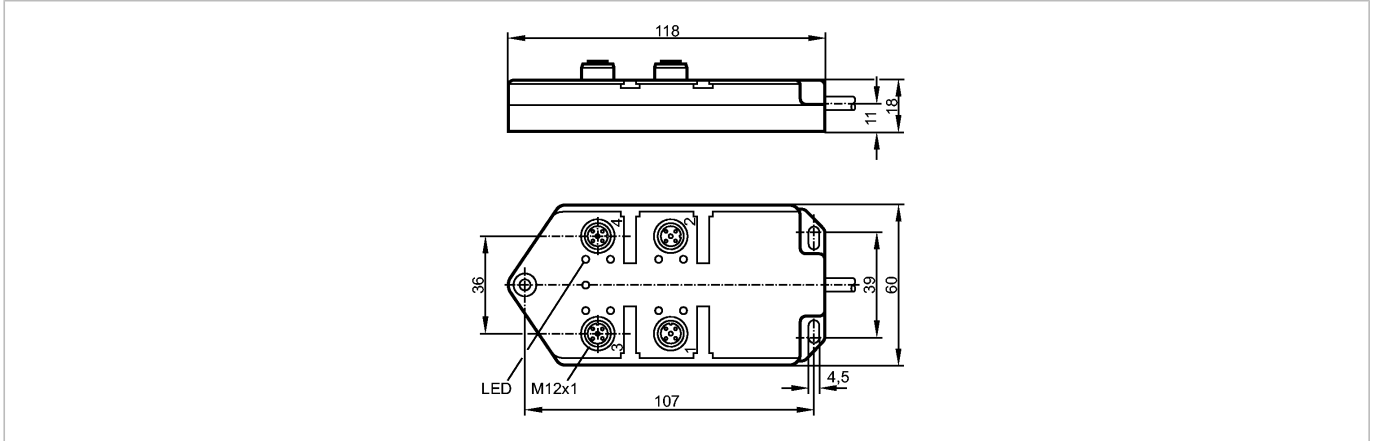

Product characteristics

Wiring block

Cable

Free from halogen

Free from silicone

gold-plated contacts

Electrical data

Electrical design

Operating voltage [V]

Max. total current load [A]

Max. current load per location [A]

Protection class

Environment

Ambient temperature [°C]

Protection

Mechanical data

Design

Housing materials

Tightening torque for knurled nut [Nm]

Weight [kg]

Displays / operating elements

Output status indication LED

Power LED

Electrical connection

Connection

Sheath color

**Wiring**

DC PNP

10...30 DC

12

4

II

-15...80

IP 67

4 way

TPU (urethane)

0.5

0.819

8 x yellow

green

PUR cable / 5 m;

8 x 0.5 mm<sup>2</sup> (63 x Ø 0.1 mm) + 3 x 1.0 mm<sup>2</sup> (127 x Ø 0.1 mm); Ø 9.3 mm; halogen-free

black

# E11017 - Wiring block - eclass: 27279201 / 27-27-92-01

- Core colors
- BN brown
  - BU blue
  - GN green
  - GY grey
  - PK pink
  - RD red
  - WH white
  - YE yellow

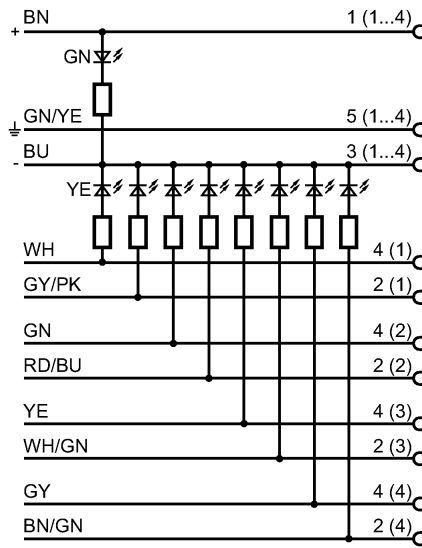
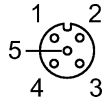

Remarks

Pack quantity

[piece]

1

Other data

Ports

M12

ifm efector, inc. • 1100 Atwater Drive • Malvern • PA 19355 — We reserve the right to make technical alterations without prior notice. — US — E11017 — 21.07.2004  
no longer available - archive entryreplaced by: EBC016