

MODEL NUMBER

DXS-LH14MMB

PRODUCT LINE

Switchbox DXP and DXS

SPECIFICATIONS

Enclosure	316 stainless steel
Bus/Sensor	HART transmitter w/ GO™ Switch SPDT
Area Classification	Explosion proof / flame proof
Visual Display	45° Green OPEN, Red CLOSED
Shaft	NAMUR 316 stainless steel
Conduit Entries	(2) M20
O-Rings	Buna-N
Pilot	No pilot device(s)
Spool Valve	No spool valve
Valve Cv	No valve Cv
Manual Override	No manual override
Regional Certification	No regional certification
N Switch	No N Switch

WIRING DIAGRAM

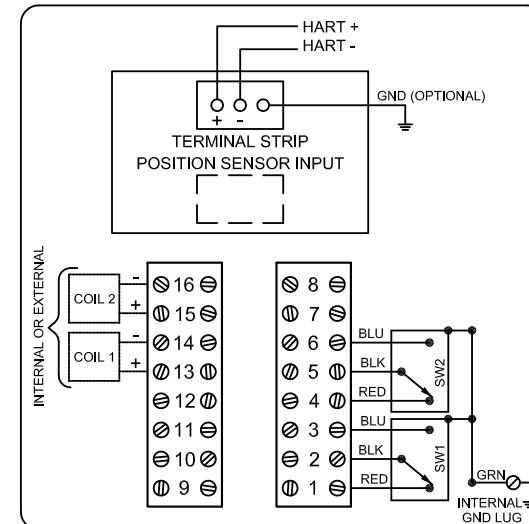

NAMEPLATE



CI I Div 1, Grps C-D; CI I Div 2, Grps A-D; Type 4X
 Ex d IIB + H₂ T6 Gb, IP66/67
 -50 C ≤ T_a ≤ 60 C
 SIRA 07ATEX1273X IECEX SIR 07.0093X
 SWITCH: SPDT 4A/120VAC; 3A/24VDC Hermetically Sealed
 HART 4-20mA; 13.5 to 39VDC, 24mA

Telemetering Equipment for use in Hazardous Locations
WARNING: Disconnect the power before servicing. Keep tightly closed during operation. Must be known to be non-hazardous area before servicing. Clean only with damp cloth.
AVERTISSEMENT: Débranchez l'alimentation avant l'entretien. Conservez hermétiquement fermé pendant le fonctionnement. Doivent être connus pour être des zones non dangereuses avant l'entretien.

TopWorx
 3300 Fern Valley Road
 Louisville, KY 40213 USA
 www.topworx.com

Model #:

Serial #:

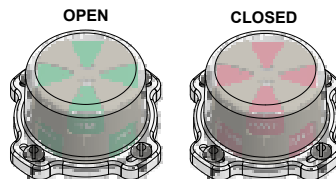

Electrol

www.electrosupply.com
 sales@electrosupply.com
 1-800-663-6576