

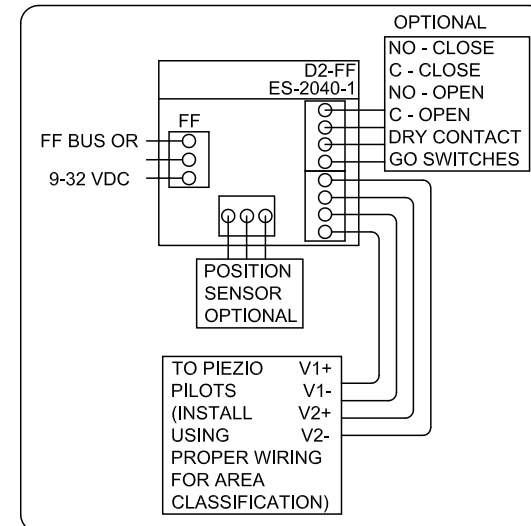

DXS-FF1GMMB

Switchbox DXP and DXS

Enclosure	316 stainless steel
Bus/Sensor	Foundation Fieldbus w/ 0-10K potentiometer
Area Classification	Explosion proof / flame proof
Visual Display	Standard 90° Green OPEN, Red CLOSED
Shaft	NAMUR 316 stainless steel
Conduit Entries	(2) M20
O-Rings	Buna-N
Pilot	No pilot device(s)
Spool Valve	No spool valve
Valve Cv	No valve Cv
Manual Override	No manual override
Regional Certification	No regional certification
N Switch	No N Switch



CI I Div 1, Grps C-D; Type 4X
 Ex d IIB + H₂ T6 Gb; IP66/67
 -50 C ≤ Ta ≤ 60 C
 SIR A 07ATEX1273X IECEX SIR 07.0093X
 BUS: 9-32VDC, 20mA

Telemetering Equipment for use in Hazardous Locations
WARNING: Disconnect the power before servicing. Keep tightly closed during operation. Must be known to be non-hazardous area before servicing. Clean only with damp cloth.
AVERTISSEMENT: Débranchez l'alimentation avant l'entretien. Conserver hermétiquement fermé pendant le fonctionnement. Doivent être connus pour être des zones non dangereuses avant l'entretien.

TopWorx
 3300 Fern Valley Road
 Louisville, KY 40213 USA
 www.topworx.com

Serial #:

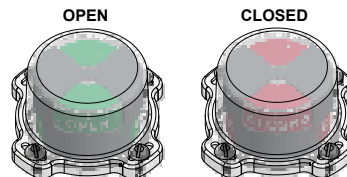

Model #:

Electrol
 www.electrosupply.com
 sales@electrosupply.com
 1-800-663-6576