

MODEL NUMBER

DXP-MH1GN6B

PRODUCT LINE

Switchbox DXP and DXS

SPECIFICATIONS

Enclosure	Tropicalized aluminum
Bus/Sensor	HART transmitter w/ mechanical SPDT
Area Classification	Explosion proof / flame proof
Visual Display	Standard 90° Green OPEN, Red CLOSED
Shaft	NAMUR 304 stainless steel
Conduit Entries	(4) 3/4" NPT
O-Rings	Buna-N
Pilot	No pilot device(s)
Spool Valve	No spool valve
Valve Cv	No valve Cv
Manual Override	No manual override
Regional Certification	No regional certification
N Switch	No N Switch

WIRING DIAGRAM

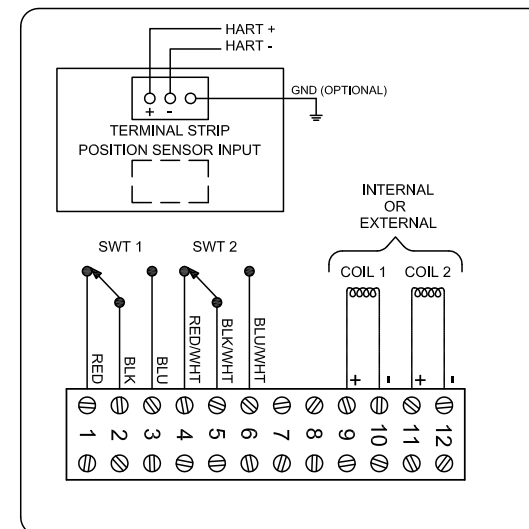

NAMEPLATE



CE 0518 Ex d IIB + H₂ T6 Gb, IP66/67 -50 C ≤ T_a ≤ 60 C
 SIRA 07ATEX1273X IECEX SIR 07.0093X
 SWITCH: SPDT 15A/125VAC, 250VAC
 HART 4-20mA: 13.5 to 39VDC, 24mA

Telemetering Equipment for use in Hazardous Locations
WARNING: Disconnect the power before servicing. Keep tightly closed during operation. Must be known to be non-hazardous area before servicing. Clean only with damp cloth.
AVERTISSEMENT: Débranchez l'alimentation avant l'entretien. Conserver hermétiquement fermé pendant le fonctionnement. Doivent être connus pour être des zones non dangereuses avant l'entretien.

TopWorx
 3300 Fern Valley Road
 Louisville, KY 40213 USA
 www.topworx.com

Model #:

Serial #:



Electrol

www.electrosupply.com
 sales@electrosupply.com
 1-800-663-6576