

## DXP-M61GSEB1A2

### Switchbox DXP and DXS

Enclosure	Tropicalized aluminum
Bus/Sensor	(6) Mechanical SPDT
Area Classification	Explosion proof / flame proof
Visual Display	Standard 90° Green OPEN, Red CLOSED
Shaft	1/4" DD 304 stainless steel
Conduit Entries	(2) 3/4" NPT
O-Rings	Buna-N
Pilot	(1) 24Vdc pilot, fail open/closed
Spool Valve	Aluminum hard coat anodized
Valve Cv	0.86 Cv (1/4" NPT Ports)
Manual Override	No manual override
Regional Certification	No regional certification
N Switch	No N Switch

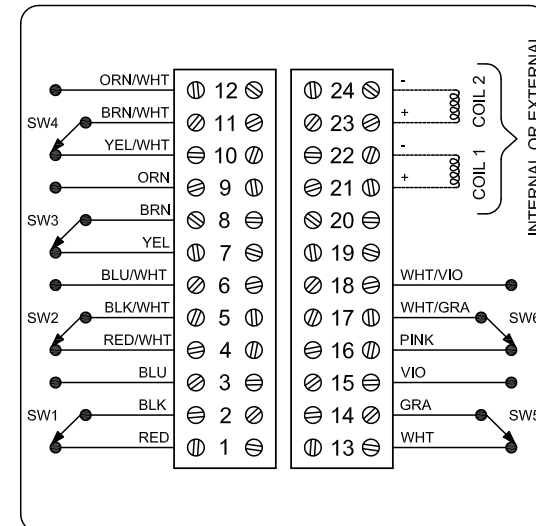

CI I Div 1, Grps C-D; Type 4X  
Ex d IIB + H<sub>2</sub>; T6 Gb; IP65  
-50 C ≤ Ta ≤ 60 C  
SIRA 07ATEX1273X IECEX SIR 07.0093X  
SWITCH: SPDT 15A/125VAC, 250VAC  
PILOT: 24 VDC

Model #:

Telemetering Equipment for use in Hazardous Locations  
**WARNING:** Disconnect the power before servicing. Keep tightly closed during operation. Must be known to be non-hazardous area before servicing. Clean only with damp cloth.  
**AVERTISSEMENT:** Débranchez l'alimentation avant l'entretien. Conserver hermétiquement fermé pendant le fonctionnement. Doivent être connus pour être des zones non dangereuses avant l'entretien.

TopWorx  
3300 Fern Valley Road  
Louisville, KY 40213 USA  
www.topworx.com

Serial #:



**Electrol**

www.electrosupply.com  
sales@electrosupply.com  
1-800-663-6576