

MODEL NUMBER

DXP-L214SEB7A2

PRODUCT LINE

Switchbox DXP and DXS

SPECIFICATIONS

Enclosure	Tropicalized aluminum
Bus/Sensor	(2) GO™ Switches SPDT hermetic seal
Area Classification	Explosion proof / flame proof
Visual Display	45° Green OPEN, Red CLOSED
Shaft	1/4" DD 304 stainless steel
Conduit Entries	(2) 3/4" NPT
O-Rings	Buna-N
Pilot	(1) 110Vac pilot, 1.1W, fail open/closed
Spool Valve	Aluminum hard coat anodized
Valve Cv	0.86 Cv (1/4" NPT Ports)
Manual Override	No manual override
Regional Certification	No regional certification
N Switch	No N Switch

WIRING DIAGRAM

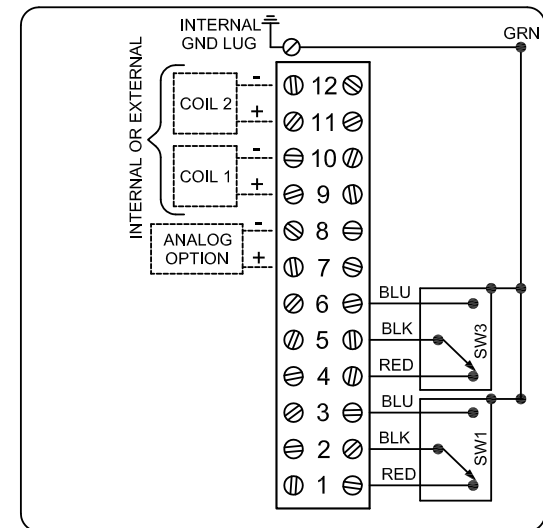

NAMEPLATE



CI I Div 1, Grps C-D; CI I Div 2, Grps A-D; Type 4X
 Ex d IIB + H3 T6 Gb, IP65
 -50 C ≤ Ta ≤ 60 C
 SIRA 07ATEX1273X IECEX SIR 07.0093X
 SWITCH: SPDT 4A/120VAC; 3A/24VDC Hermetically Sealed
 PILOT: 110 VAC

Telemetering Equipment for use in Hazardous Locations
WARNING: Disconnect the power before servicing. Keep tightly closed during operation. Must be known to be non-hazardous area before servicing. Clean only with damp cloth.
AVERTISSEMENT: Débranchez l'alimentation avant l'entretien. Conserver hermétiquement fermé pendant le fonctionnement. Doivent être connus pour être des zones non dangereuses avant l'entretien.

TopWorx
 3300 Fern Valley Road
 Louisville, KY 40213 USA
 www.topworx.com

Model #:

Serial #:

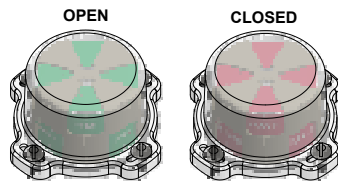

Electrol

www.electrosupply.com
 sales@electrosupply.com
 1-800-663-6576