

MODEL NUMBER

DXP-L20GNMS0000R

PRODUCT LINE

Switchbox DXP and DXS

SPECIFICATIONS

Enclosure	Tropicalized aluminum
Bus/Sensor	(2) GO™ Switches SPDT hermetic seal
Area Classification	Intrinsically safe
Visual Display	Standard 90° Green OPEN, Red CLOSED
Shaft	NAMUR 304 stainless steel
Conduit Entries	(2) M20
O-Rings	Silicone
Pilot	No pilot device(s)
Spool Valve	No spool valve
Valve Cv	No valve Cv
Manual Override	No manual override
Regional Certification	EAC
N Switch	No N Switch

WIRING DIAGRAM

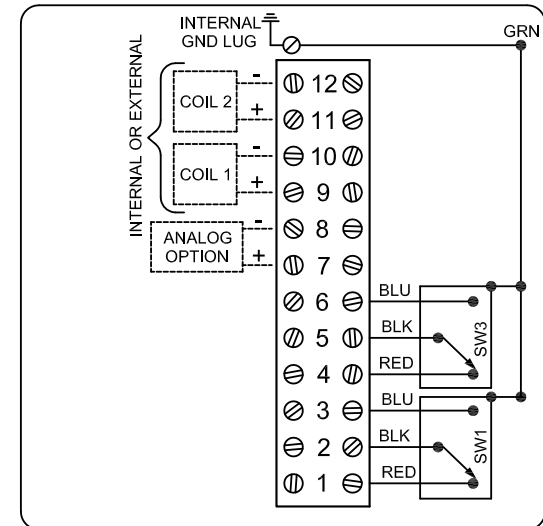

NAMEPLATE



0 Ex ia IIC T4 Ga X; Ex tb IIC T135° C Db; IP66/67
 -50°C ≤ Ta ≤ 55°C
 TC RU C-US, E608.B.02500
 SWITCH: Ui=28V, Ii=100mA, Pi=0.7W, Ci=0, Li=0

Telemetering Equipment for use in Hazardous Locations
WARNING: Substitution of components may impair intrinsic safety. The installer shall confirm which certified sub-assemblies are fitted and ensure compliance with the entry parameters in the appropriate certificate. Potential electrostatic charging hazard - Clean only with damp cloth.

TopWorx
 3300 Fern Valley Road
 Louisville, KY 40213 USA
 www.topworx.com

Model #:

Serial #:



Electrol

www.electrosupply.com
 sales@electrosupply.com
 1-800-663-6576