

MODEL NUMBER

DXP-FF2GNEB

PRODUCT LINE

Switchbox DXP and DXS

SPECIFICATIONS

Enclosure	Tropicalized aluminum
Bus/Sensor	Foundation Fieldbus w/ 0-10K potentiometer
Area Classification	Non-incendive
Visual Display	Standard 90° Green OPEN, Red CLOSED
Shaft	NAMUR 304 stainless steel
Conduit Entries	(2) 3/4" NPT
O-Rings	Buna-N
Pilot	No pilot device(s)
Spool Valve	No spool valve
Valve Cv	No valve Cv
Manual Override	No manual override
Regional Certification	No regional certification
N Switch	No N Switch

WIRING DIAGRAM

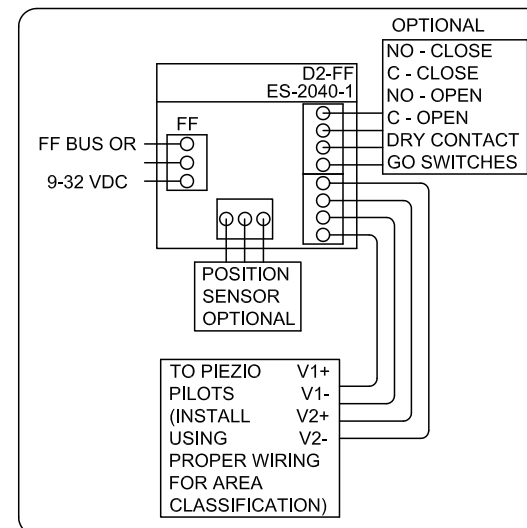

NAMEPLATE



Class I Div 2, Grps A-D, Type 4X
 Ex nC IIC T6 Gc; IP66/67
 -20°C ≤ Ta ≤ 50°C
 Install per Control Drawing ES-03468-1

Telemetry Equipment for use In Hazardous Locations
WARNING: Substitution of components may impair suitability for use in Class I, Division 2 or Zone 2 environments. Must be known to be non-hazardous area before servicing. Clean only with damp cloth.
AVERTISSEMENT: La substitution de composants peut altérer l'aptitude pour une utilisation dans Classe I, Division 2 environnements. Doivent être connus pour être des zones non dangereuses avant l'entretien.

TopWorx
 3300 Fern Valley Road
 Louisville, KY 40213 USA
 www.topworx.com

Model #:

Serial #:

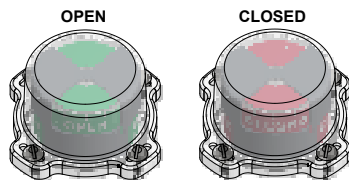

Electrol

www.electrosupply.com
 sales@electrosupply.com
 1-800-663-6576