

**MODEL NUMBER**

**DXP-FF1XNMBP62**

**PRODUCT LINE**

**Switchbox DXP and DXS**

**SPECIFICATIONS**

Enclosure	Tropicalized aluminum
Bus/Sensor	Foundation Fieldbus w/ 0-10K potentiometer
Area Classification	Explosion proof / flame proof
Visual Display	45° Black OPEN, Yellow CLOSED
Shaft	NAMUR 304 stainless steel
Conduit Entries	(2) M20
O-Rings	Buna-N
Pilot	(1) piezo pilot, fail open/closed
Spool Valve	316 stainless steel
Valve Cv	0.86 Cv (1/4" NPT Ports)
Manual Override	No manual override
Regional Certification	No regional certification
N Switch	No N Switch

**WIRING DIAGRAM**

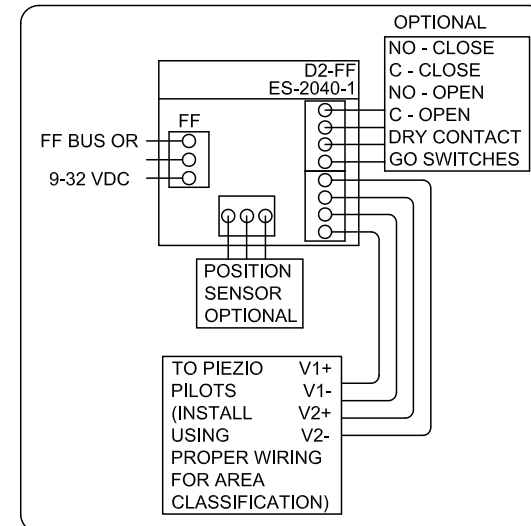

**NAMEPLATE**



CI I Div 1, Grps C-D; Type 4X  
 Ex d IIB + H<sub>2</sub> T6 Gb; IP65  
 -50 C ≤ T<sub>a</sub> ≤ 60 C  
 SIR A 07ATEX1273X IECEx SIR 07.0093X  
 BUS: 9-32VDC, 20mA

**Telemetering Equipment for use in Hazardous Locations**  
**WARNING:** Disconnect the power before servicing. Keep tightly closed during operation. Must be known to be non-hazardous area before servicing. Clean only with damp cloth.  
**AVERTISSEMENT:** Débranchez l'alimentation avant l'entretien. Conserver hermétiquement fermé pendant le fonctionnement. Doivent être connus pour être des zones non dangereuses avant l'entretien.

TopWorx  
 3300 Fern Valley Road  
 Louisville, KY 40213 USA  
 www.topworx.com

Model #:

Serial #:

**OPEN**

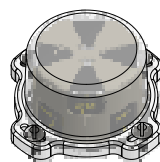

**CLOSED**

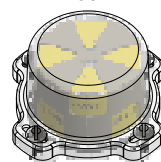

www.electrosupply.com  
 sales@electrosupply.com  
 1-800-663-6576