

DXP-FF1GSEBR62

Switchbox DXP and DXS

Enclosure	Tropicalized aluminum
Bus/Sensor	Foundation Fieldbus w/ 0-10K potentiometer
Area Classification	Explosion proof / flame proof
Visual Display	Standard 90° Green OPEN, Red CLOSED
Shaft	1/4" DD 304 stainless steel
Conduit Entries	(2) 3/4" NPT
O-Rings	Buna-N
Pilot	(2) piezo pilots, fail last position
Spool Valve	316 stainless steel
Valve Cv	0.86 Cv (1/4" NPT Ports)
Manual Override	No manual override
Regional Certification	No regional certification
N Switch	No N Switch

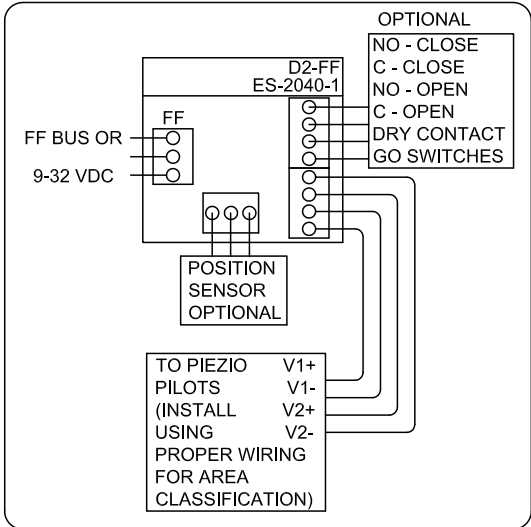
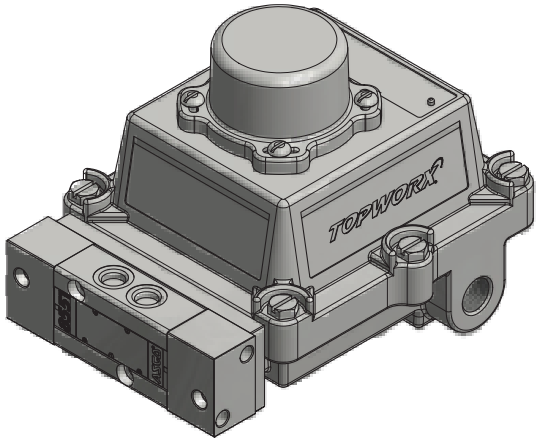
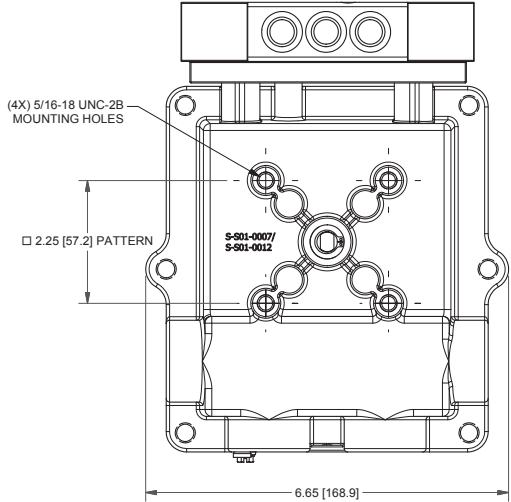
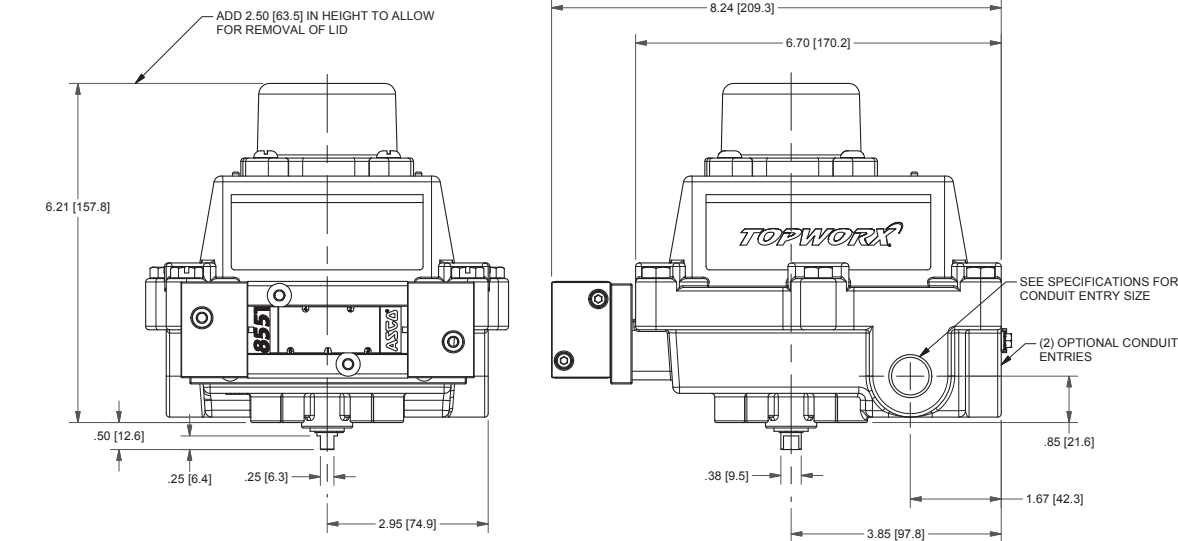

CI I Div 1, Grps C-D; Type 4X  
Ex d IIB + H<sub>2</sub> T6 Gb; IP65  
-50 C ≤ Ta ≤ 60 C  
SIRA 07ATEX1273X IECEX SIR 07.0093X  
BUS: 9-32VDC, 20mA

Telemetering Equipment for use in Hazardous Locations  
**WARNING:** Disconnect the power before servicing. Keep tightly closed during operation. Must be known to be non-hazardous area before servicing. Clean only with damp cloth.  
**AVERTISSEMENT:** Débranchez l'alimentation avant l'entretien. Conserver hermétiquement fermé pendant le fonctionnement. Doivent être connus pour être des zones non dangereuses avant l'entretien.

TopWorx  
3300 Fern Valley Road  
Louisville, KY 40213 USA  
www.topworx.com

Serial #:

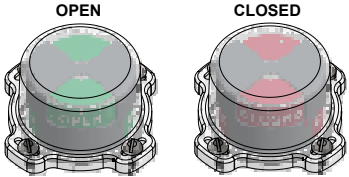

Model #:

**Electrol**

www.electrosupply.com  
sales@electrosupply.com  
1-800-663-6576