

MODEL NUMBER

DXP-FF1GNEBRA3

PRODUCT LINE

Switchbox DXP and DXS

SPECIFICATIONS

Enclosure	Tropicalized aluminum
Bus/Sensor	Foundation Fieldbus w/ 0-10K potentiometer
Area Classification	Explosion proof / flame proof
Visual Display	Standard 90° Green OPEN, Red CLOSED
Shaft	NAMUR 304 stainless steel
Conduit Entries	(2) 3/4" NPT
O-Rings	Buna-N
Pilot	(2) piezo pilots, fail last position
Spool Valve	Aluminum hard coat anodized
Valve Cv	3.7 Cv (1/2" NPT Ports)
Manual Override	No manual override
Regional Certification	No regional certification
N Switch	No N Switch

WIRING DIAGRAM

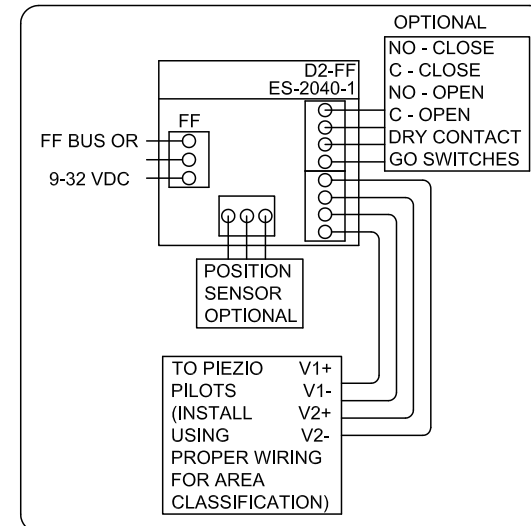

NAMEPLATE



CI I Div 1, Grps C-D, Type 4X
 Ex d IIB + H₂ T6 Gb, IP65
 -50 C ≤ Ta ≤ 60 C
 SIR A 07ATEX1273X IECEx SIR 07.0093X
 BUS: 9-32VDC, 20mA

Telemetering Equipment for use in Hazardous Locations
WARNING: Disconnect the power before servicing. Keep tightly closed during operation. Must be known to be non-hazardous area before servicing. Clean only with damp cloth.
AVERTISSEMENT: Débranchez l'alimentation avant l'entretien. Conserver hermétiquement fermé pendant le fonctionnement. Doivent être connus pour être des zones non dangereuses avant l'entretien.

TopWorx
 3300 Fern Valley Road
 Louisville, KY 40213 USA
 www.topworx.com

Model #:

Serial #:

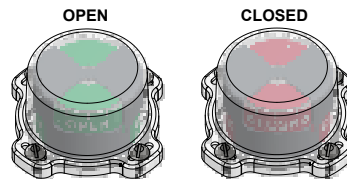

Electrol

www.electrosupply.com
 sales@electrosupply.com
 1-800-663-6576