

MODEL NUMBER

DXP-FF1BNEBPA21

PRODUCT LINE

Switchbox DXP and DXS

SPECIFICATIONS

Enclosure	Tropicalized aluminum
Bus/Sensor	Foundation Fieldbus w/ 0-10K potentiometer
Area Classification	Explosion proof / flame proof
Visual Display	90° Black OPEN, Yellow CLOSED
Shaft	NAMUR 304 stainless steel
Conduit Entries	(2) 3/4" NPT
O-Rings	Buna-N
Pilot	(1) piezo pilot, fail open/closed
Spool Valve	Aluminum hard coat anodized
Valve Cv	0.86 Cv (1/4" NPT Ports)
Manual Override	Single pushbutton momentary/latching
Regional Certification	No regional certification
N Switch	No N Switch

WIRING DIAGRAM

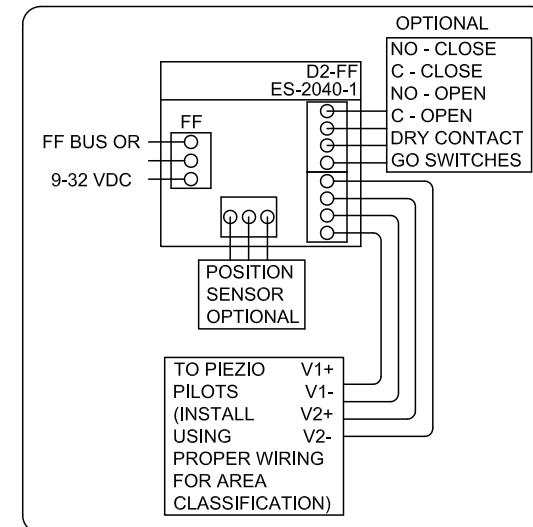

NAMEPLATE



CI I Div 1, Grps C-D; Type 4X
Ex d IIB + H₂; T6 Gb; IP65
-50 C ≤ Ta ≤ 60 C
SIRA 07ATEX1273X IECEX SIR 07.0093X
BUS: 9-32VDC, 20mA

Telemetering Equipment for use In Hazardous Locations
WARNING: Disconnect the power before servicing. Keep tightly closed during operation. Must be known to be non-hazardous area before servicing. Clean only with damp cloth.
AVERTISSEMENT: Débranchez l'alimentation avant l'entretien. Conserver hermétiquement fermé pendant le fonctionnement. Doivent être connus pour être des zones non dangereuses avant l'entretien.

TopWorx
3300 Fern Valley Road
Louisville, KY 40213 USA
www.topworx.com

Model #:

Serial #:

OPEN

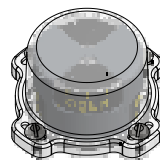

CLOSED

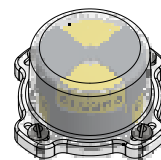

Electrol

www.electrosupply.com
sales@electrosupply.com
1-800-663-6576