

**MODEL NUMBER**

**DXP-ES1GN3B1A2**

**PRODUCT LINE**

**Switchbox DXP and DXS**

**SPECIFICATIONS**

Enclosure	Tropicalized aluminum
Bus/Sensor	ESD/PST module w/ GO™ Switch
Area Classification	Explosion proof / flame proof
Visual Display	Standard 90° Green OPEN, Red CLOSED
Shaft	NAMUR 304 stainless steel
Conduit Entries	(4) M20
O-Rings	Buna-N
Pilot	(1) 24Vdc pilot, fail open/closed
Spool Valve	Aluminum hard coat anodized
Valve Cv	0.86 Cv (1/4" NPT Ports)
Manual Override	No manual override
Regional Certification	No regional certification
N Switch	No N Switch

**WIRING DIAGRAM**

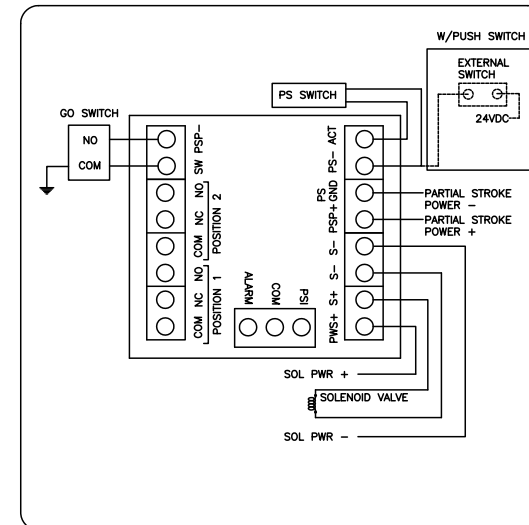

**NAMEPLATE**



Telemetering Equipment for use in Hazardous Locations  
**WARNING:** Disconnect the power before servicing. Keep tightly closed during operation. Must be known to be non-hazardous area before servicing. Clean only with damp cloth.  
**AVERTISSEMENT:** Débranchez l'alimentation avant l'entretien. Conservez hermétiquement fermé pendant le fonctionnement. Doivent être connus pour être des zones non dangereuses avant l'entretien.

CI I Div 1, Grps C-D; CI I Div 2, Grps A-D; Type 4X  
 Ex d IIB + H<sub>2</sub> T6 Gb, IP65  
 -50 C ≤ T<sub>a</sub> ≤ 60 C  
 SIRA 07ATEX1273X IECEX SIR 07.0093X  
 Electrical Rating: 250mA/24VDC, 120VAC  
 PILOT: 24 VDC

TopWorx  
 3300 Fern Valley Road  
 Louisville, KY 40213 USA  
 www.topworx.com

Model #:

Serial #:

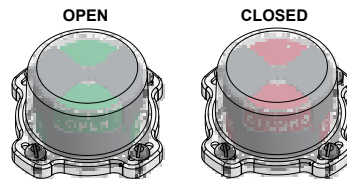

www.electrosupply.com  
 sales@electrosupply.com  
 1-800-663-6576