

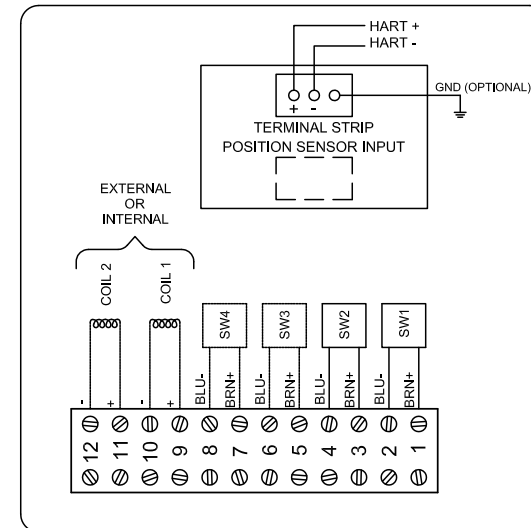

# DXP-EH0GNMB

## Switchbox DXP and DXS

Enclosure	Tropicalized aluminum
Bus/Sensor	HART transmitter w/ P+F NJ2-V3-N inductive NAMUR
Area Classification	Intrinsically safe
Visual Display	Standard 90° Green OPEN, Red CLOSED
Shaft	NAMUR 304 stainless steel
Conduit Entries	(2) M20
O-Rings	Buna-N
Pilot	No pilot device(s)
Spool Valve	No spool valve
Valve Cv	No valve Cv
Manual Override	No manual override
Regional Certification	No regional certification
N Switch	No N Switch



Ex ia IIC T6 Gb; IP66/67  
 -50°C ≤ Ta ≤ 52°C  
 SIR4 14ATEX2241X IECEx SIR 14.0078X  
 SWITCH: Ui=16V, Ii=25mA, Pi=34mW (Reference Cert for Ci and Li)  
 HART 4-20mA: Ui=28V, Ii=100mA, Pi=0.7W, Ci=14nF, Li=2.06mH

Telemetering Equipment for use in Hazardous Locations  
**WARNING:** Substitution of components may impair intrinsic safety. The installer shall confirm which certified sub-assemblies are fitted and ensure compliance with the entry parameters in the appropriate certificate. Potential electrostatic charging hazard - Clean only with damp cloth.

TopWorx  
 3300 Fern Valley Road  
 Louisville, KY 40213 USA  
 www.topworx.com  
**Serial #:**

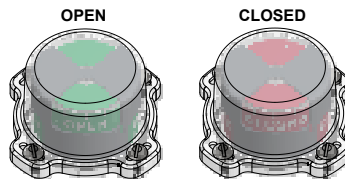

Model #: