

## DXP-E20ZNEB

### Switchbox DXP and DXS

Enclosure	Tropicalized aluminum
Bus/Sensor	(2) P+F NJ2-V3-N inductive NAMUR
Area Classification	Intrinsically safe
Visual Display	45° Yellow OPEN, Black CLOSED
Shaft	NAMUR 304 stainless steel
Conduit Entries	(2) 3/4" NPT
O-Rings	Buna-N
Pilot	No pilot device(s)
Spool Valve	No spool valve
Valve Cv	No valve Cv
Manual Override	No manual override
Regional Certification	No regional certification
N Switch	No N Switch

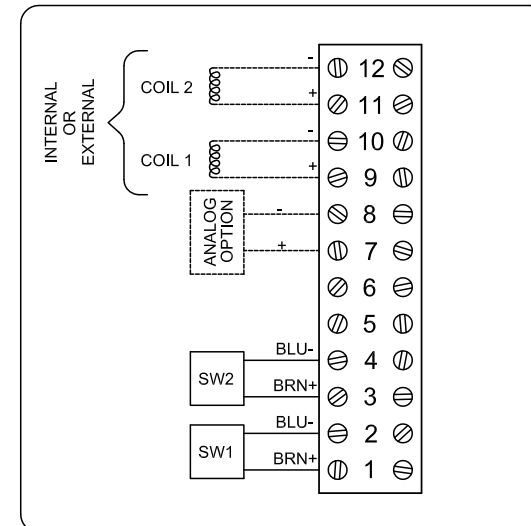

CI I Div 1, Grps A-D; Type 4X  
 Ex Ia IIC T6 Gb; IP66/67  
 -50°C ≤ Ta ≤ 60°C  
 SIRA 14ATEX2241X IECEx SIR 14.0078X  
 Intrinsically Safe - Exia / Sécurité Intrinsèque  
 Install per Control Drawing S-K136

Model #:

**Telemetering Equipment for use In Hazardous Locations**  
**WARNING:** Substitution of components may impair intrinsic safety. The installer shall confirm which certified sub-assemblies are fitted and ensure compliance with the entity parameters in the appropriate certificate. Potential electrostatic charging hazard - Clean only with damp cloth.

**AVERTISSEMENT:** La substitution de composants peut compromettre la sécurité intrinsèque.

TopWorx  
 3300 Fern Valley Road  
 Louisville, KY 40213 USA  
 www.topworx.com

Serial #:

**Electrol**

www.electrosupply.com  
 sales@electrosupply.com  
 1-800-663-6576