



MODEL NUMBER

DXP-E204N4B

PRODUCT LINE

Switchbox DXP and DXS

SPECIFICATIONS

Enclosure	Tropicalized aluminum
Bus/Sensor	(2) P+F NJ2-V3-N inductive NAMUR
Area Classification	Intrinsically safe
Visual Display	45° Green OPEN, Red CLOSED
Shaft	NAMUR 304 stainless steel
Conduit Entries	(2) 3/4" NPT, (2) 1/2" NPT
O-Rings	Buna-N
Pilot	No pilot device(s)
Spool Valve	No spool valve
Valve Cv	No valve Cv
Manual Override	No manual override
Regional Certification	No regional certification
N Switch	No N Switch

WIRING DIAGRAM

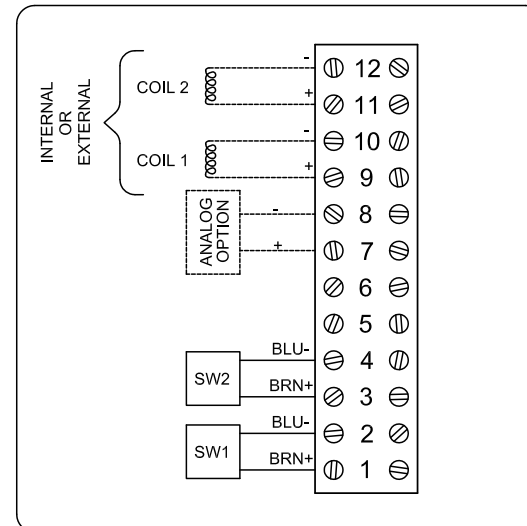

NAMEPLATE



CI I Div 1, Grps A-D; Type 4X
 Ex Ia IIC T6 Gb, IP66/67
 -50 C ≤ Ta ≤ 60 C
 SIRA 14ATEX2241X IECEx SIR 14.0078X
 Intrinsically Safe - Exia / Sécurité Intrinsèque
 Install per Control Drawing S-K136

Telemetering Equipment for use In Hazardous Locations

WARNING: Substitution of components may impair intrinsic safety. The installer shall confirm which certified sub-assemblies are fitted and ensure compliance with the entity parameters in the appropriate certificate. Potential electrostatic charging hazard - Clean only with damp cloth.

AVERTISSEMENT: La substitution de composants peut compromettre la sécurité intrinsèque.

TopWorx
 3300 Fern Valley Road
 Louisville, KY 40213 USA
 www.topworx.com

Model #:

Serial #:

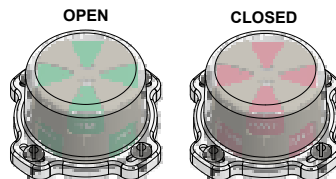

Electrol

www.electrosupply.com
 sales@electrosupply.com
 1-800-663-6576