

DXP-DN1BSEB1A21

Switchbox DXP and DXS

Enclosure	Tropicalized aluminum
Bus/Sensor	DeviceNet w(2) SPDT GO Switches
Area Classification	Explosion proof / flame proof
Visual Display	90° Black OPEN, Yellow CLOSED
Shaft	1/4" DD 304 stainless steel
Conduit Entries	(2) 3/4" NPT
O-Rings	Buna-N
Pilot	(1) 24Vdc pilot, fail open/closed
Spool Valve	Aluminum hard coat anodized
Valve Cv	0.86 Cv (1/4" NPT Ports)
Manual Override	Single pushbutton momentary/latching
Regional Certification	No regional certification
N Switch	No N Switch

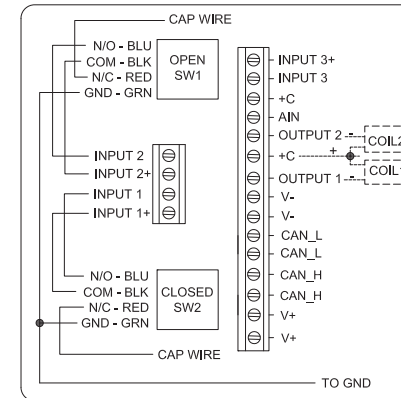

CI I Div 1, Grps C-D; CI I Div 2, Grps A-D; Type 4X
 Ex d IIB + H₂ T6 Gb, IP65
 -40 C ≤ T_a ≤ 50 C
 SIRA 07ATEX1273X IECEX SIR 07.0093X
 BUS: Max Current 500mA @ Max Voltage 25VDC
 PILOT: 24 VDC

Model #:

Telemetering Equipment for use in Hazardous Locations
WARNING: Disconnect the power before servicing. Keep tightly closed during operation. Must be known to be non-hazardous area before servicing. Clean only with damp cloth.
AVERTISSEMENT: Débranchez l'alimentation avant l'entretien. Conserver hermétiquement fermé pendant le fonctionnement. Doivent être connus pour être des zones non dangereuses avant l'entretien.

TopWorx
 3300 Fern Valley Road
 Louisville, KY 40213 USA
 www.topworx.com

Serial #:

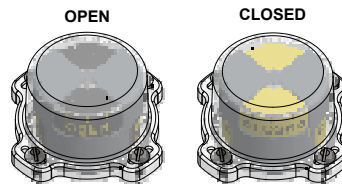

Electrol
 www.electrosupply.com
 sales@electrosupply.com
 1-800-663-6576