

DXP-AS1YNEB1A2

Switchbox DXP and DXS

Enclosure	Tropicalized aluminum
Bus/Sensor	AS-Interface w(2) SPDT GO Switches
Area Classification	Explosion proof / flame proof
Visual Display	90° Yellow OPEN, Black CLOSED
Shaft	NAMUR 304 stainless steel
Conduit Entries	(2) 3/4" NPT
O-Rings	Buna-N
Pilot	(1) 24Vdc pilot, fail open/closed
Spool Valve	Aluminum hard coat anodized
Valve Cv	0.86 Cv (1/4" NPT Ports)
Manual Override	No manual override
Regional Certification	No regional certification
N Switch	No N Switch

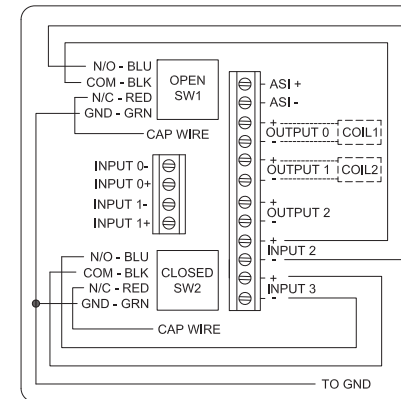

CI I Div 1, Grps C-D; CI I Div 2, Grps A-D; Type 4X
Ex d IIB + H₂ T6 Gb, IP65
-40 C ≤ T_a ≤ 50 C
SIRA 07ATEX1273X IECEX SIR 07.0093X
BUS: Max Current 400mA @ Max ASI Voltage 31.6VDC
PILOT: 24 VDC

Model #:

Telemetering Equipment for use in Hazardous Locations
WARNING: Disconnect the power before servicing. Keep tightly closed during operation. Must be known to be non-hazardous area before servicing. Clean only with damp cloth.
AVERTISSEMENT: Débranchez l'alimentation avant l'entretien. Conserver hermétiquement fermé pendant le fonctionnement. Doivent être connus pour être des zones non dangereuses avant l'entretien.

TopWorx
3300 Fern Valley Road
Louisville, KY 40213 USA
www.topworx.com

Serial #:

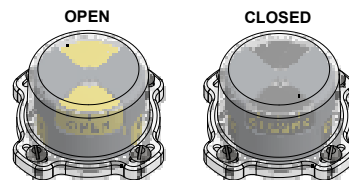

Electrol

www.electrosupply.com
sales@electrosupply.com
1-800-663-6576