

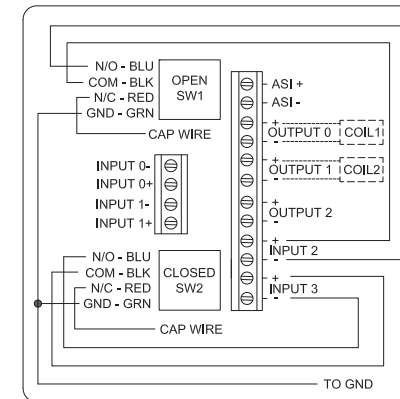

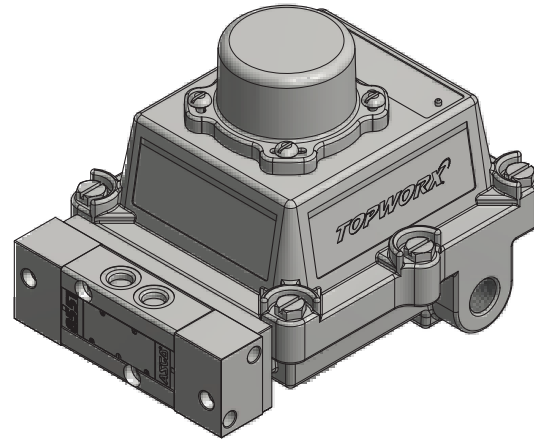
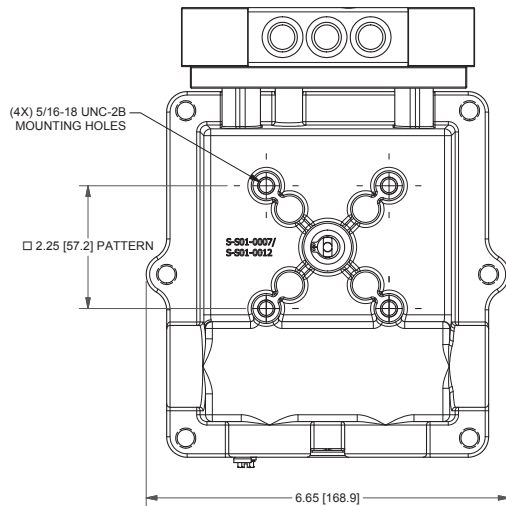
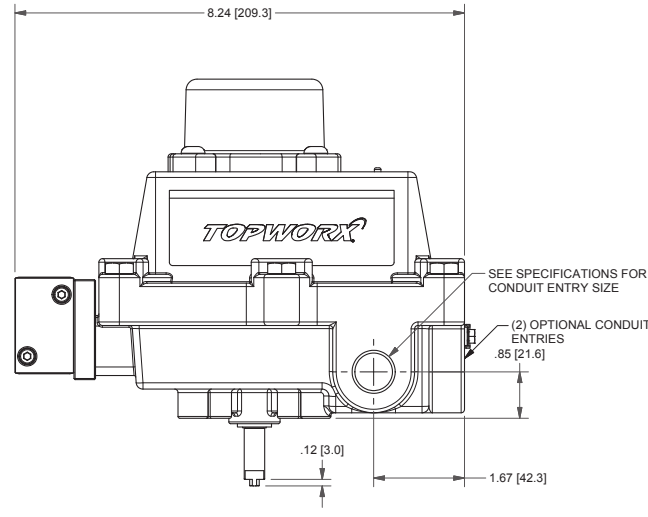
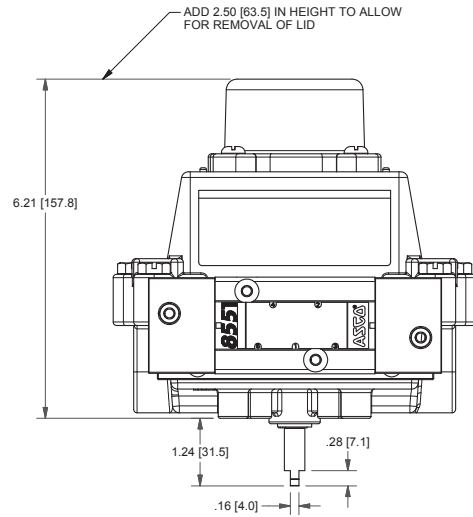

DXP-AS1GNEB2A2

Switchbox DXP and DXS

Enclosure	Tropicalized aluminum
Bus/Sensor	AS-Interface w(2) SPDT GO Switches
Area Classification	Explosion proof / flame proof
Visual Display	Standard 90° Green OPEN, Red CLOSED
Shaft	NAMUR 304 stainless steel
Conduit Entries	(2) 3/4" NPT
O-Rings	Buna-N
Pilot	(2) 24Vdc pilots, fail last position
Spool Valve	Aluminum hard coat anodized
Valve Cv	0.86 Cv (1/4" NPT Ports)
Manual Override	No manual override
Regional Certification	No regional certification
N Switch	No N Switch



 0518  II 2 G  CERTIFIED
 LISTED
 E125326
 USA

CI I Div 1, Grps C-D; CI I Div 2, Grps A-D; Type 4X
 Ex d IIB + H₂ T6 Gb, IP65
 -40 C ≤ T_a ≤ 50 C
 SIRA 07ATEX1273X IECEX SIR 07.0093X
 BUS: Max Current 400mA @ Max Asi Voltage 31.6VDC
 PILOT: 24 VDC

Model #:

Telemetering Equipment for use In Hazardous Locations
WARNING: Disconnect the power before servicing. Keep tightly closed during operation. Must be known to be non-hazardous area before servicing. Clean only with damp cloth.
AVERTISSEMENT: Débranchez l'alimentation avant l'entretien. Conservez hermétiquement fermé pendant le fonctionnement. Doivent être connus pour être des zones non dangereuses avant l'entretien.

TopWorx
 3300 Fern Valley Road
 Louisville, KY 40213 USA
 www.topworx.com

Serial #:

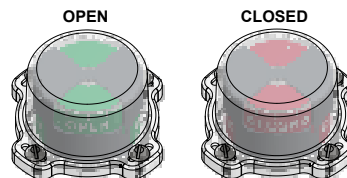

www.electrosupply.com
sales@electrosupply.com
 1-800-663-6576