

DXP-0X2GN4B2A2

Switchbox DXP and DXS

Enclosure	Tropicalized aluminum
Bus/Sensor	4-20mA transmitter
Area Classification	Non-incendive
Visual Display	Standard 90° Green OPEN, Red CLOSED
Shaft	NAMUR 304 stainless steel
Conduit Entries	(2) 3/4" NPT, (2) 1/2" NPT
O-Rings	Buna-N
Pilot	(2) 24Vdc pilots, fail last position
Spool Valve	Aluminum hard coat anodized
Valve Cv	0.86 Cv (1/4" NPT Ports)
Manual Override	No manual override
Regional Certification	No regional certification
N Switch	No N Switch

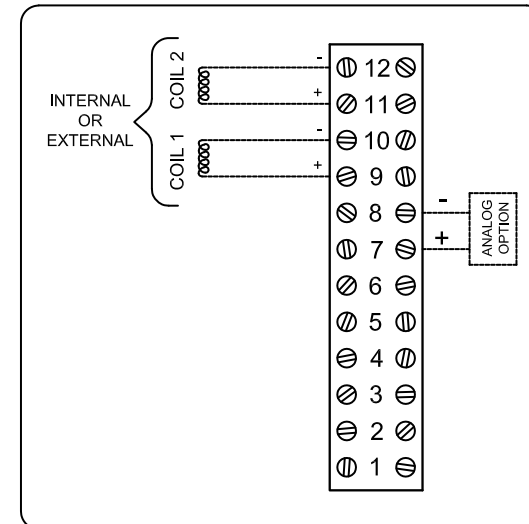
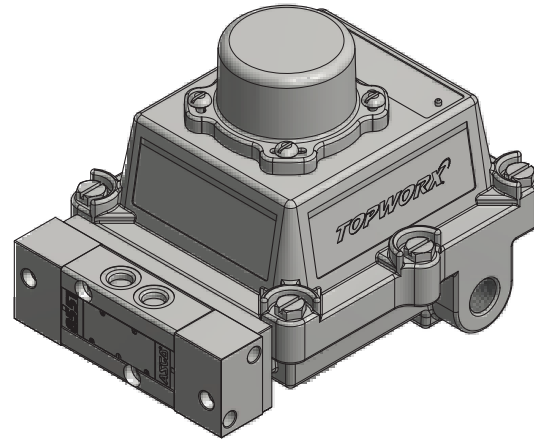
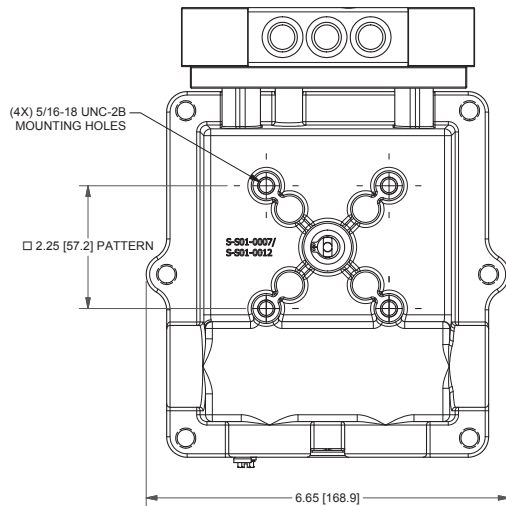
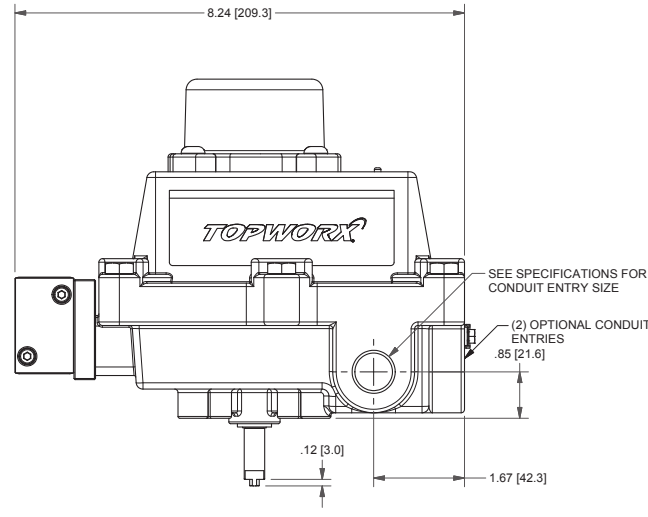
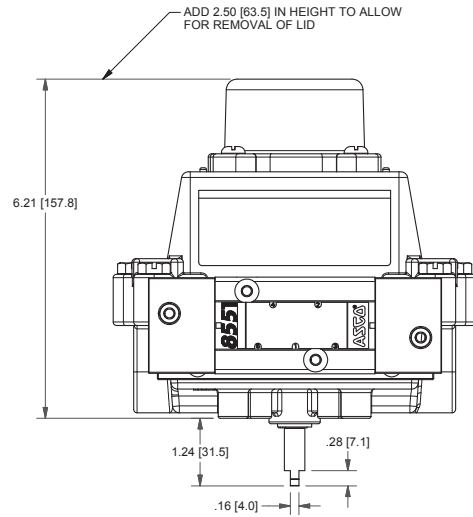

CI I Div 2, Grps A-D, Type 4X
 Ex nA nC IIC T6 Gc; IP65
 -50°C ≤ Ta ≤ 60°C
 4-20mA LOOP: 8.5 to 34VDC, 20mA
 PILOT: 24 VDC

Model #:

Telemetering Equipment for use In Hazardous Locations
WARNING: Substitution of components may impair suitability for use in Class I, Division 2 or Zone 2 environments. Must be known to be non-hazardous area before servicing. Clean only with damp cloth.

AVERTISSEMENT: La substitution de composants peut altérer l'aptitude pour une utilisation dans Classe I, Division 2 environnements. Doivent être connus pour être des zones non dangereuses avant l'entretien.

TopWorx
 3300 Fern Valley Road
 Louisville, KY 40213 USA
 www.topworx.com

Serial #:

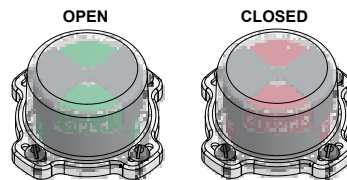

Electrol
www.electrosupply.com
sales@electrosupply.com
 1-800-663-6576