

MODEL NUMBER

DXP-0X1GNEB1A2

PRODUCT LINE

Switchbox DXP and DXS

SPECIFICATIONS

Enclosure	Tropicalized aluminum
Bus/Sensor	4-20mA transmitter
Area Classification	Explosion proof / flame proof
Visual Display	Standard 90° Green OPEN, Red CLOSED
Shaft	NAMUR 304 stainless steel
Conduit Entries	(2) 3/4" NPT
O-Rings	Buna-N
Pilot	(1) 24Vdc pilot, fail open/closed
Spool Valve	Aluminum hard coat anodized
Valve Cv	0.86 Cv (1/4" NPT Ports)
Manual Override	No manual override
Regional Certification	No regional certification
N Switch	No N Switch

WIRING DIAGRAM

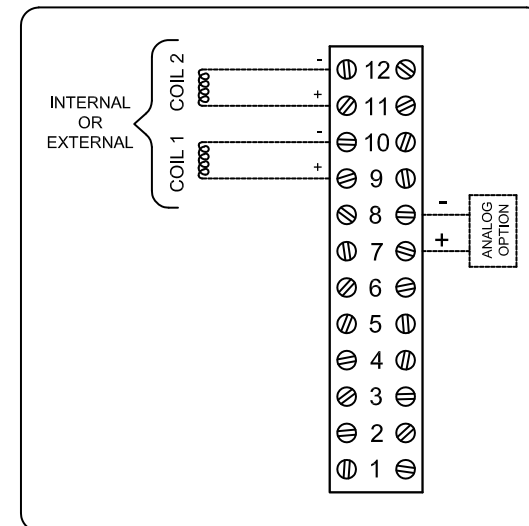

NAMEPLATE



CI I Div 1, Grps C-D; CI I Div 2, Grps A-D; Type 4X
Ex d IIB + H₂ T6 Gb, IP65
-50 C ≤ T_a ≤ 60 C
SIRA 07ATEX1273X IECEX SIR 07.0093X
4-20mA LOOP: 8.5 to 34VDC, 20mA
PILOT: 24 VDC

Telemetering Equipment for use in Hazardous Locations
WARNING: Disconnect the power before servicing. Keep tightly closed during operation. Must be known to be non-hazardous area before servicing. Clean only with damp cloth.
AVERTISSEMENT: Débranchez l'alimentation avant l'entretien. Conservez hermétiquement fermé pendant le fonctionnement. Doivent être connus pour être des zones non dangereuses avant l'entretien.

TopWorx
3300 Fern Valley Road
Louisville, KY 40213 USA
www.topworx.com

Model #:

Serial #:



Electrol

www.electrosupply.com
sales@electrosupply.com
1-800-663-6576