

no longer available - archive entry replaced by: DD0296  
 Article discontinued as of 31.March 2015

**ecomat200**

DD0022



D100/230VAC/10-10K

Evaluation systems, power supplies

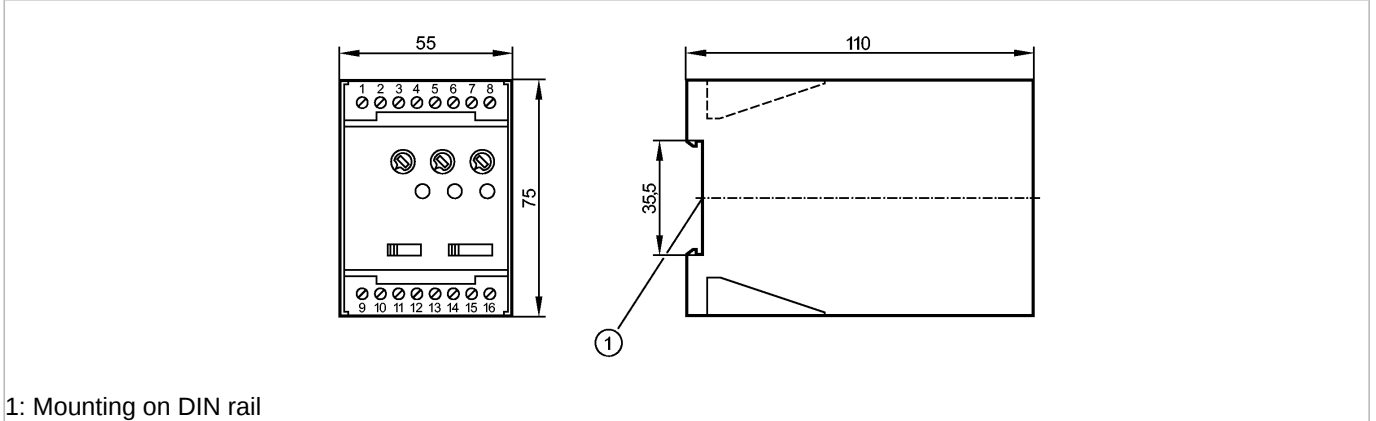

1: Mounting on DIN rail



Product characteristics

Speed monitor

D100

Housing for DIN rail mounting

Application

Application

evaluation of pulse sequences with regard to overspeed and underspeed; rotational speed monitoring

Switching function

F1-F4, with 4-step slide switch

Switching output

relay (1 changeover contact)

Electrical data

Nominal voltage [V]

230 AC (50...60 Hz) / 24 DC

Voltage tolerance [%]

± 10

Sensor supply [V]

24 DC (max. 30mA)

Inputs

Digital

1

Input frequency (max.) [pulses/min]

15000 (250 Hz)

Outputs

Relay

Relay

1

Contact rating

8 A / 1250 VA / 250 V AC

Measuring / setting range

Setting range [pulses/min.]

10...10000

Adjustment of the switch point

3 ranges preselectable, fine adjustment with potentiometer

Hysteresis [% of Sp]

5...100

Start-up delay [s]

0.5...15

Accuracy / deviations

Repeatability [% / Sp]

1

Environment

Ambient temperature [°C]

-20...70

Protection housing / terminals

IP 40 / IP 20

Safety classification

MTTF [a]

469

Mechanical data

Housing materials

plastics

Weight [kg]

0.414

Displays / operating elements

Power LED

green

Input pulses LED

yellow

**DD0022 - Speed monitor - eclass: 27230220 / 27-23-02-20**

Output status indication LED green (lights when the output relay is energised)

Electrical connection

Connection 16 terminals...2.5 mm<sup>2</sup>

**Wiring**

- 01: n.c.
- 02: n.c.
- 03: DC Sensor supply (-)
- 04: sensor signal pnp
- 05: DC Sensor supply (+)
- 06: DC Supply voltage (-)
- 07: DC Supply voltage (+)
- 08: n.c.
- 09: n.c.
- 10: n.c.
- 11: n.c.
- 12: Relay (normally closed)
- 13: Relay (common)
- 14: Relay (normally open)
- 15: AC Supply voltage (L)
- 16: AC Supply voltage (N)

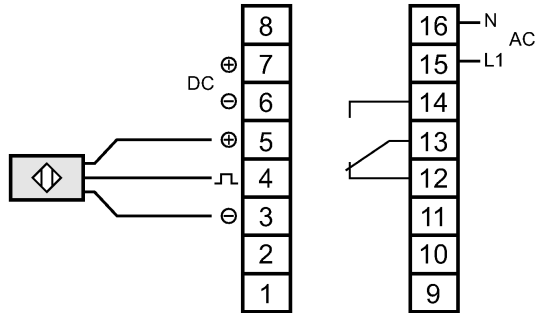

n.c. = not connected

Remarks

Pack quantity [piece] 1

ifm efector, inc. • 1100 Atwater Drive • Malvern • PA 19355 — We reserve the right to make technical alterations without prior notice. — US — DD0022 — 09.12.2014  
 no longer available - archive entry replaced by: DD0296  
 Article discontinued as of 31.March 2015