

D12FPH Series DIN Rail High Power Fiber Optic Sensors

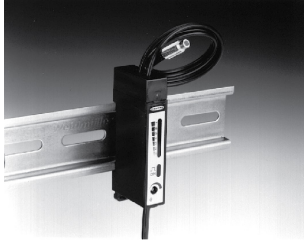

Datasheet

Very High Power Sensors For Use With Plastic Fiber Optic Assemblies



- Plastic fiber optic sensors for DIN rail mounting
- Highest optical power available in a plastic fiber optic sensor
- Visible red light source; for use with Banner cut-to-length plastic fiber optic assemblies
- Choice of either NPN (sinking) or PNP (sourcing) complementary outputs; 150 mA maximum (continuous) load
- Normally closed output of most models may be wired as a diagnostic alarm output, depending on hookup to power supply¹
- LED indicators for Power On and N.O. Output Conducting
- 7-segment LED bargraph² indicates received signal strength, output overload, and marginal excess gain



WARNING: Not To Be Used for Personnel Protection

Never use this device as a sensing device for personnel protection. Doing so could lead to serious injury or death. This device does not include the self-checking redundant circuitry necessary to allow its use in personnel safety applications. A sensor failure or malfunction can cause either an energized or de-energized sensor output condition.

Models

Model ³	Output Type	Connection	Range
D12SN6FPH	NPN	2 m (6.5-ft) attached cable	See the performance curves
D12SN6FPHQ	NPN	152 mm (6-in) cable with pico-style QD	
D12SP6FPH	PNP	2 m (6.5-ft) attached cable	
D12SP6FPHQ	PNP	152 mm (6-in) with pico-style QD	

Overview

D12 sensors are compact, self-contained visible-red fiber optic sensors for DIN rail mounting. D12 sensors are designed for use with Banner cut-to-length plastic fiber optic assemblies. They may be used in the opposed and diffuse fiber optic sensing modes. D12FPH Series sensors have the highest optical power available in a plastic fiber optic sensor.

All models operate from 10 V dc to 30 V dc and draw 45 mA maximum, exclusive of load current. Models are available with a choice of NPN or PNP complementary outputs (one output normally open, one output normally closed). The normally closed output may be used as a diagnostic alarm output, depending on the wiring of the sensor to the power supply⁴. All models are available with either an attached cable or a 6-inch cable with a pico-style quick disconnect connector.

Each output is capable of 150 mA continuous load. The choice of NPN (sinking) or PNP (sourcing) models enables D12 sensors to interface to a wide variety of loads.

Either the small diameter (0.254 mm and 0.508 mm/0.010 inch and 0.020 inch) or the large diameter (1.06 mm/0.040 inch) Banner cut-to-length plastic fibers can be used.

¹ U.S. Patent #5087838

² U.S. Patent #4965548

³ Models with 30-foot attached cable are also available.

⁴ U.S. Patent #5087838



LED Indicators

Two top-mounted LED indicators:

- Green = dc power on
- Amber = Normally Open Output Conducting

Seven-Segment Moving-Dot LED Bargraph⁵

A red seven-segment moving-dot LED bargraph illuminates to indicate the relative strength of the received light signal. This feature simplifies the sensitivity adjustment and fiber optic alignment, and provides a constant reference over time for overall sensing system performance.

Segment #1 of the bargraph flashes to indicate an output overload.

Segment #7 flashes to indicate marginal excess gain.

A flashing LED corresponds to the On state of the D12 sensor's alarm output.

Sensitivity Control

D12s have a 15-turn sensitivity control, with a slotted brass screw clutched at both ends of travel.

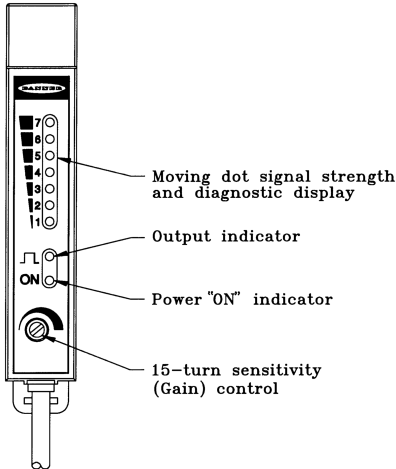
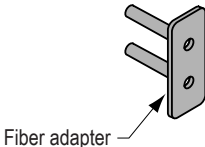

Figure 1. Features

Installing Plastic Fibers

1. Cut the fiber ends according to the instructions included with the fibers.
2. Slide the fiber gripper up (open).
3. If you are using 0.010 inch or 0.020 inch (0.254 mm and 0.508 mm) diameter fibers: Insert the adaptor into the ports as far as it will go.



4. For all fiber diameters: Insert the prepared plastic fiber sensor ends gently into the ports as far as they will go.
5. Slide the fiber gripper back down to lock it.

Wiring Diagrams

NPN (Sinking) Standard Wiring

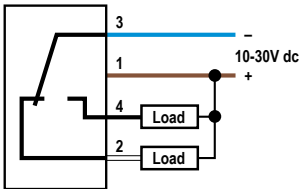

NPN (Sinking) Alarm Wiring

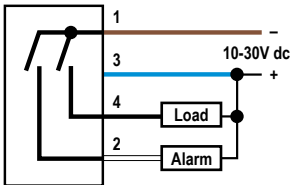

PNP (Sourcing) Standard Wiring

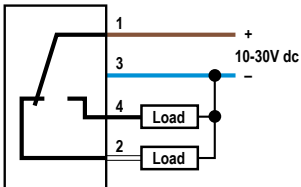

PNP (Sourcing) Alarm Wiring

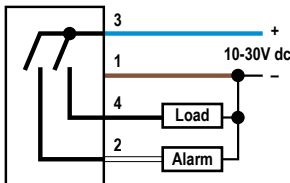

⁵ U.S. Patent #4965548

Specifications

Sensing Range

See the excess gain curves; [Performance Curves](#) on page 4

Sensing Beam

Visible red, 660 nm

Supply Voltage

10 V dc to 30 V dc at 45 mA maximum, exclusive of load
Protected against reverse polarity and inductive load transients

Output Configurations

Solid-state dc complementary outputs; see the models table for details.
The normally closed (N.C.) output of standard FP and FV models may be used as an alarm output, depending upon the hookup to the power supply.

Output Rating

Complementary outputs, one normally open (N.O.) and the other normally closed (N.C.). 150 mA maximum each output. No false pulse on power-up. (False pulse protection circuit causes a 20 ms delay on power-up.) Short-circuit protected.
Off-state leakage current <10 μ A at 30 V dc
On-state saturation voltage <1 V at 10 mA dc; <1.5 V at 150 mA dc
The total load may not exceed 150 mA

Response Time

0.5 ms on; 0.5 ms off
Repeatability is 130 μ s
Response time and repeatability are independent of signal strength.

Adjustments

All models have a sensitivity control on top of the module (15-turn slotted brass screw, clutched at both ends of travel).

Construction

Black ABS housing with acrylic cover. The fiber clamping element is acetal.

Connections

2 m (6.5-ft) or 9 m (30-foot) attached PVC-covered cable, or 6-inch cable with pico-style 4-pin QD connector
Models also available with 9 m (30 ft) attached cable

Mounting Bracket

D12 Series sensors mount directly to a standard DIN rail, or may be through-hole mounted using the supplied mounting bracket and M3 \times 0.5 hardware
Bracket material is black PBT polyester; mounting hardware is stainless steel

Environmental Rating

NEMA 2

Operating Conditions

Operating Temperature: -20 $^{\circ}$ C to +70 $^{\circ}$ C (-4 $^{\circ}$ F to +158 $^{\circ}$ F)
90% at +50 $^{\circ}$ C maximum relative humidity (non-condensing)

Application Notes

D12 sensors are designed to deliver very high optical energy (excess gain). They should not be used for applications which offer low optical contrast (that is, only a small difference in received light levels between the light and dark sensing conditions). Examples include diffuse mode sensing of objects in front of a reflective background and opposed mode sensing of non-opaque materials.

D12 sensors excel in applications requiring high excess gain (for example, for long-range sensing, sensing with long fiber lengths, diffuse sensing of materials with low reflectivity, etc.).

Required Overcurrent Protection



WARNING: Electrical connections must be made by qualified personnel in accordance with local and national electrical codes and regulations.

Overcurrent protection is required to be provided by end product application per the supplied table.

Overcurrent protection may be provided with external fusing or via Current Limiting, Class 2 Power Supply.

Supply wiring leads < 24 AWG shall not be spliced.

For additional product support, go to <http://www.bannerengineering.com>.

Supply Wiring (AWG)	Required Overcurrent Protection (Amps)
20	5.0
22	3.0
24	2.0
26	1.0
28	0.8
30	0.5

Certifications



Dimensions

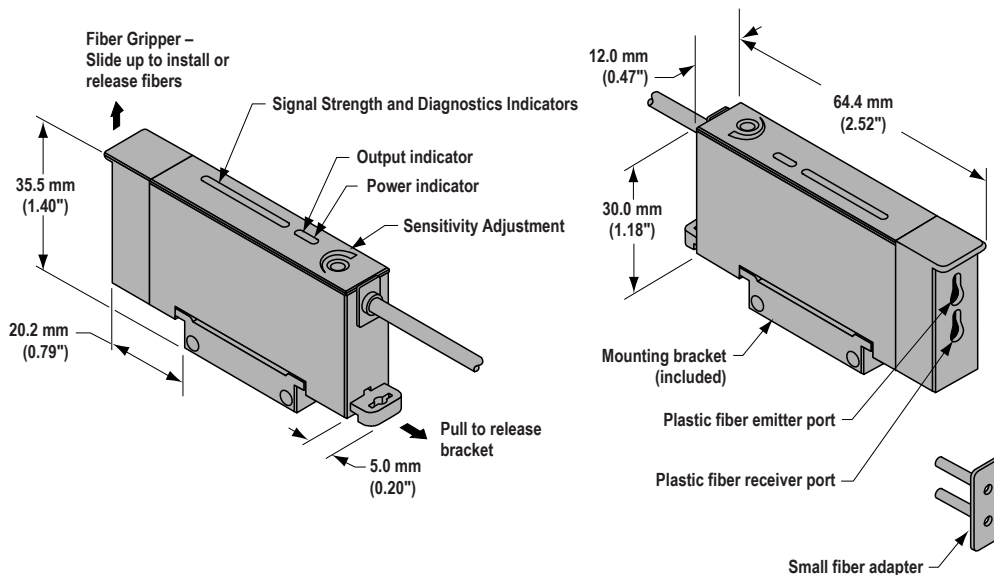

Dimensions—D12 Bracket

D12 Sensors mount directly to a standard 35 mm DIN rail, or may be through-hole mounted using the supplied mounting bracket and stainless steel M3 × 0.5 hardware.

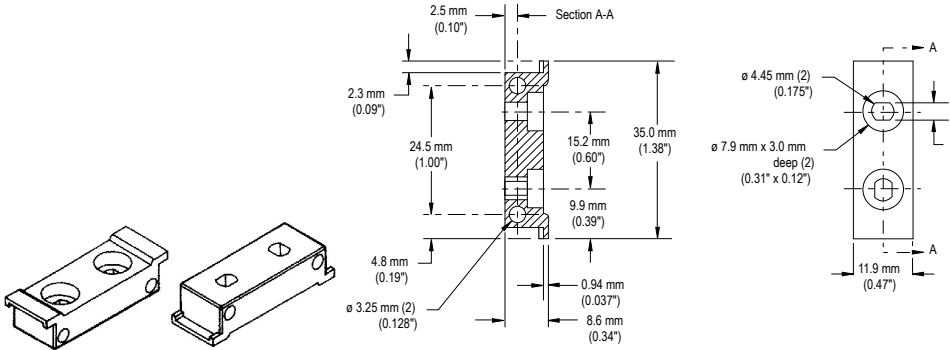

Performance Curves

Diffuse Sensing Mode

Excess gain curves for bifurcated plastic fibers:

0.020 Inch Fibers

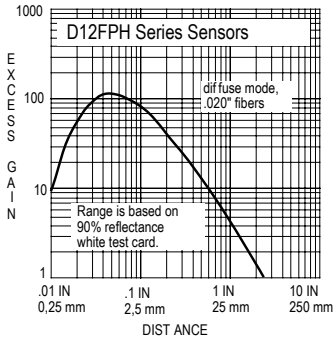

0.040 Inch Fibers

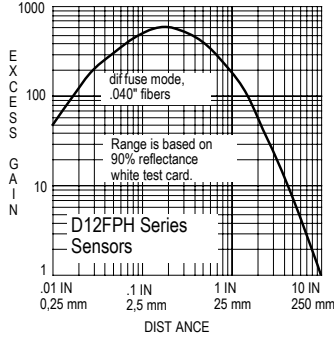

Opposed Sensing Mode

Excess gain curves for individual plastic fibers:

0.020 Inch Fibers

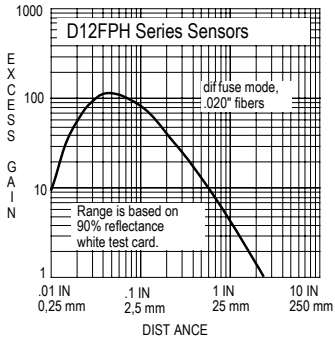

0.040 Inch Fibers

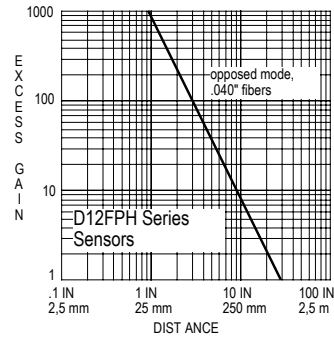

Two Individual Underterminated 0.040-in Diameter Plastic Fibers, Each With a L08FP Lens

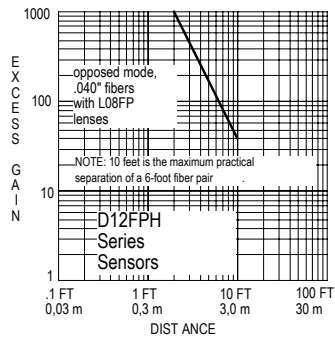

Two Individual Threaded 0.040-in Diameter Plastic Fibers (PIT4 Series), Each with a L2 Lens

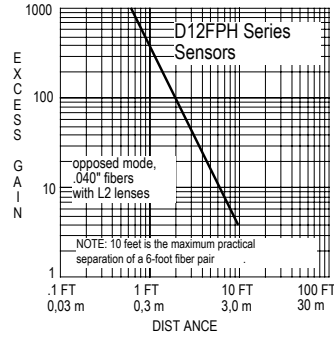

NOTE:

- In both lens situations, the curves stop at 10 feet separation (the maximum practical separation of the sensing ends for a pair of 6-foot single fibers).
- A pair of 6-foot cut-to-length individual plastic fibers with factory-installed L08FP lenses is also available. Order plastic fiber assembly model PIL46U.

Accessories

4-Pin Snap-on M8/Pico-Style Cordsets				
Model	Length	Style	Dimensions	Pinout (Female)
PKG4-2	2 m (6.56 ft)	Straight		<p>1 = Brown 2 = White 3 = Blue 4 = Black</p>
PKW4Z-2	2 m (6.56 ft)	Right-Angle		

Lenses

L2

- Glass

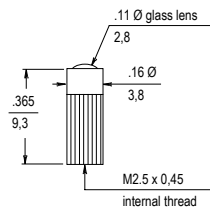

L08FP

- Plastic and acrylic

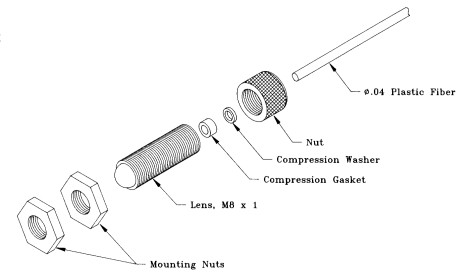

Banner Engineering Corp. Limited Warranty

Banner Engineering Corp. warrants its products to be free from defects in material and workmanship for one year following the date of shipment. Banner Engineering Corp. will repair or replace, free of charge, any product of its manufacture which, at the time it is returned to the factory, is found to have been defective during the warranty period. This warranty does not cover damage or liability for misuse, abuse, or the improper application or installation of the Banner product.

THIS LIMITED WARRANTY IS EXCLUSIVE AND IN LIEU OF ALL OTHER WARRANTIES WHETHER EXPRESS OR IMPLIED (INCLUDING, WITHOUT LIMITATION, ANY WARRANTY OF MERCHANTABILITY OR FITNESS FOR A PARTICULAR PURPOSE), AND WHETHER ARISING UNDER COURSE OF PERFORMANCE, COURSE OF DEALING OR TRADE USAGE.

This Warranty is exclusive and limited to repair or, at the discretion of Banner Engineering Corp., replacement. IN NO EVENT SHALL BANNER ENGINEERING CORP. BE LIABLE TO BUYER OR ANY OTHER PERSON OR ENTITY FOR ANY EXTRA COSTS, EXPENSES, LOSSES, LOSS OF PROFITS, OR ANY INCIDENTAL, CONSEQUENTIAL OR SPECIAL DAMAGES RESULTING FROM ANY PRODUCT DEFECT OR FROM THE USE OR INABILITY TO USE THE PRODUCT, WHETHER ARISING IN CONTRACT OR WARRANTY, STATUTE, TORT, STRICT LIABILITY, NEGLIGENCE, OR OTHERWISE.

Banner Engineering Corp. reserves the right to change, modify or improve the design of the product without assuming any obligations or liabilities relating to any product previously manufactured by Banner Engineering Corp.

Copyright Notice

Any misuse, abuse, or improper application or installation of this product or use of the product for personal protection applications when the product is identified as not intended for such purposes will void the product warranty. Any modifications to this product without prior express approval by Banner Engineering Corp will void the product warranties. All specifications published in this document are subject to change: Banner reserves the right to modify product specifications or update documentation at any time. For the most recent version of any documentation, refer to: www.bannerengineering.com. © Banner Engineering Corp. All rights reserved.