

Article discontinued as of 30. June 2017

ecomat100[®]

CR1053



R360/PDM360/compact/MONO-E

Control systems for mobile vehicles

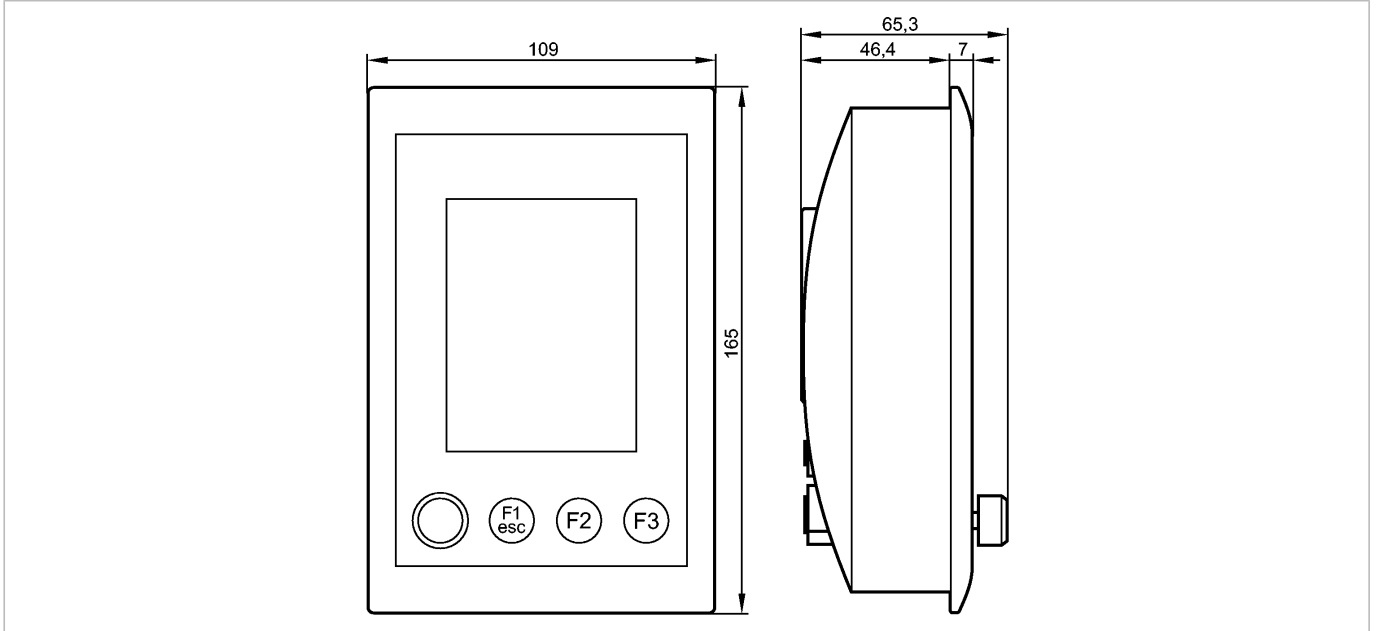

Product characteristics

Datasheet in PDF format: CR1053.pdf

Process and dialogue module PDM360 compact	
Programmable graphic display for controlling, parameter-setting and operation of mobile machines and plants	
3.8" monochrome display	
3 freely programmable backlit function keys	
Encoder with pushbutton	
2 inputs / 2 outputs	
Real-time clock	
Ethernet	
Programming according to IEC 61131-3	
10...32 V DC	
display	
Display	3.8" monochrome display
Resolution pixels [pixel]	240 x 320
Background lighting	LED
Inputs	
Digital	2
Outputs	
Digital	2
Interfaces	
CAN	1
Ethernet	1
RS-232	1
Mechanical data	
Type of mounting	panel/surf.
Weight [kg]	1.465
Displays / operating elements	
Operating elements	3 Pushbuttons 1 Encoder with pushbutton

CR1053 - Process and dialogue module PDM360 compact - eclass: 27249290 / 27-24-92-90

Electrical connection

Connection

M12 connector

Remarks

Pack quantity

[piece]

1

ifm efector, inc. • 1100 Atwater Drive • Malvern • PA 19355 — We reserve the right to make technical alterations without prior notice. — US — CR1053 — 28.01.2015

Article discontinued as of 30. June 2017